

**Rough Terrain Crane Features | RT700 Series****ROUGH TERRAIN CRANE
RT700 SERIES****FEATURES**

- ▶ 75-80 tons (68-72 mt) maximum lifting capacity
- ▶ 126' (38.4 m) maximum boom length
- ▶ 134' (40.8 m) maximum tip height
- ▶ 275 horsepower engine
- ▶ Electo-Proportional Joystick Controls
- ▶ Swingaway jib offsettable to 0°, 15° or 30°
- ▶ Two-speed main and auxiliary winches
- ▶ Quick reeving boom head and hook block
- ▶ Fully independent multi-position out and down outriggers
- ▶ Environmental operator's cab optimizes load visibility and productivity
- ▶ RCI 510 load system Rated Capacity Indicator
- ▶ 12 month crane warranty and 5 year warranty on major weldments



**TEREX®**

ROUGH TERRAIN CRANE

RT700**RT700 SERIES****ROUGH TERRAIN CRANES**RT775 75 ton (68 mt)
RT780 80 ton (72 mt)**FEATURES**

- ▶ 126' (38.4 m) four section, full power boom with foot pedal control
- ▶ High strength, four plate construction welded inside and out with embossed side plate holes to reduce weight and increase strength.
- ▶ Single boom hoist cylinder provides boom elevation of -4° to 78° for easier reeving changes and close radius operation.
- ▶ Quick reeving boom head; no need to remove wedge from socket.
- ▶ 360° house lock standard.

ENVIRONMENTAL OPERATOR'S CAB

- ▶ Rated Capacity Indicator (RCI) system including anti-two block system with automatic function disconnects.
- ▶ Deluxe six-way adjustable operator's seat has mechanical suspension and head and arm rests.
- ▶ Sound and weather Insulated for comfort.
- ▶ Removable front window, hinged tinted glass skylight, and sliding right hand window.
- ▶ Armrest mounted dual axis controls for winch(s), swing, and boom elevation; foot control pedals for swing brake, boom telescope, and throttle.
- ▶ Complete instrumentation. Environmentally-sealed rocker switches.
- ▶ Circuit breakers in cab.

RUGGED EASY-TO-MANEUVER CARRIER

- ▶ Box-type chassis construction with reinforcing cross members.
- ▶ Chassis is Terex designed and built with 4x4x4 drive.
- ▶ Full power-shift transmission with integral torque converter; neutral safety start; six speeds forward and reverse.
- ▶ Hydraulic four-wheel power steering for 2-wheel, 4-wheel or crab steer.
- ▶ Split system over hydraulic disc brakes.
- ▶ Fully independent hydraulic outriggers may be utilized fully extended to 26' (7.9 m), in their 1/2 extended position, or fully retracted.
- ▶ Tail swing only 14' (4.3 m)
- ▶ Standard Cummins QSB6.7 275 horsepower engine. (205 kW)
- ▶ Earthmover style 29.5 x 25 28 P.R. tires.

**POWERFUL TWO-SPEED WINCHES**

- ▶ 489 fpm (149 m/min) maximum line speed, 18,450 lb (8 369 kg) maximum line pull. Armrest mounted control
- ▶ Integral automatic brake.
- ▶ Electronic drum rotation indicators.
- ▶ Winch drum rollers, tapered drum flanges..

HIGH CAPACITY, DEPENDABLE HYDRAULIC SYSTEM

- ▶ Three gear type pumps, one single and two in tandem, driven off the transmission. combined system capability is 120 gpm (455 lpm). Includes pump disconnect on tandem pump. Hydraulic reservoir with 178 gal (674 L) capacity and full flow oil filtration system.

OPTIONS INCLUDE

- ▶ 32' or 33 to 57' (9.8 or 10.0 to 17.4 m) swing-on jib. Both offset to 0°, 15° or 30°.
- ▶ Heater/defroster, air conditioner for operator's cab
- ▶ Auxiliary winch with rope.
- ▶ Work lights.
- ▶ Cold weather kit for cab.
- ▶ Independent rear wheels steering.
- ▶ AM/FM cassette radio.

TEREX Cranes
106-12th Street S.E.
Waverly, Iowa 50677-9466 USATEL (319) 352-3920 FAX (319) 352-5727
EMAIL inquire@terexwaverly.com
WEB terex-cranes.com

Disclaimer: Effective Date: March, 2008. Product specifications and prices are subject to change without notice or obligation. The photographs and/or drawings in this document are for illustrative purposes only. Refer to the appropriate Operator's Manual for instructions on the proper use of this equipment. Failure to follow the appropriate Operator's Manual when using our equipment or to otherwise act irresponsibly may result in serious injury or death. The only warranty applicable to our equipment is the standard written warranty applicable to the particular product and sale and Terex makes no other warranty, express or implied. Products and services listed may be trademarks, service marks or trade-names of Terex Corporation and/or its subsidiaries in the USA and other countries.

All rights are reserved. Terex® is a registered trademark of Terex Corporation in the USA and many other countries.
Copyright 2008 Terex Corporation.

PRINTED IN U.S.

NOVEMBER 26, 2008
P/N: RT700SF

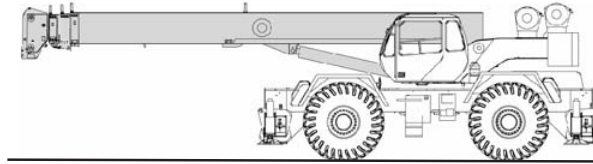
ROUGH TERRAIN CRANE
RT700 SERIES**Rough Terrain Crane Specifications | RT700 Series****STANDARD BOOM EQUIPMENT****BOOM**

40-126' (12.2 - 38.4 m), four section full power boom. Telescoping is mechanically synchronized with single lever control. The synchronization system consists of a single telescope cylinder and high strength leaf chains to extend and retract the third section and the tip section. The boom is a high-strength four plate design, welded inside and out with anti-friction slide pads. Boom side plates are made with stamped impressions to reduce weight and increase strength. A single boom hoist cylinder provides for boom elevation of -4 to 78 degrees. Maximum tip height 134' (40.8 m).

BOOM HEAD

Welded to fourth section of boom. Five or six metallic load sheaves and two idler sheaves mounted on heavy duty, anti-friction bearings. Quick reeving boom head. Provisions made for side-stow jib mounting.

OPTIONAL BOOM EQUIPMENT**JIBS**

32' (9.8 m) side stow swing-on one-piece lattice type jib. Single nylon sheave mounted on anti-friction bearing. Jib is offsettable at 0°, 15°, or 30°. Maximum tip height is 165' (50.3 m).

33-57' (10.1 - 17.4 m) side stow swing-on lattice type jib. Single nylon sheave mounted on anti-friction bearing. Jib is extendible to 57' (17.4 m) by means of a 25' (7.6 m) manual pull-out tip section, roller supported for ease of extension. Jib is offsettable at 0°, 15°, or 30°. Maximum tip height is 190' (57.9 m).

BOOM HEAD

Welded to fourth section of boom. Five or six nylon load sheaves and two idler sheaves mounted on heavy duty, anti-friction bearings. Quick reeving boom head. Provisions made for side-stow jib mounting.

AUXILIARY BOOM HEAD

Removable auxiliary boom head has single nylon sheave mounted on anti-friction bearing. Removable pin-type rope guard for quick reeving. Installs on main boom peak only. Removal is not required for jib use.

HOOK BLOCK

Five metallic sheaves on anti-friction bearings with hook and hook latch. Quick reeving design does not require removal of wedge and socket from rope.

HOOK & BALL

12 ton (10.9 mt) top swivel ball with hook and hook latch.



ROUGH TERRAIN CRANE RT700 SERIES

STANDARD UPPERSTRUCTURE EQUIPMENT

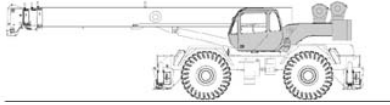

UPPERSTRUCTURE FRAME

All welded one-piece structure fabricated with high tensile strength alloy steel. Counterweight is bolted to frame.

TURNTABLE CONNECTION

Swing bearing is a single row, ball type, with internal teeth. The swing bearing is bolted to the revolving upperstructure and to the carrier frame.

SWING

A hydraulic motor drives a double planetary reduction gear for precise and smooth swing function. Swing speed (no load) is 2.2 rpm.

SWING BRAKE

Heavy duty multiple disc swing brake is mechanically actuated from operator's cab by foot pedal. Brake may be locked on or used as a momentary brake. A 360° mechanical house lock is standard.

RATED CAPACITY INDICATOR

Rated Capacity Indicator with visual and audible warning system and automatic function disconnects. Second generation pictographic display includes: boom radius, boom angle, boom length, allowable load, actual load, and percentage of allowable load registered by bar graph. Operator settable alarms provided for swing angle, boom length, boom angle, tip height, and work area exclusion zone. Anti-two block system includes audio/visual warning and automatic function disconnects.

OPERATORS CAB

Environmental cab with all steel construction, optimum visibility, tinted safety glass throughout, and rubber floor matting is mounted on vibration absorbing pads. The cab has a sliding door on the left side, framed sliding window on the right side, hinged tinted all glass skylight and removable front windshield to provide optimum visibility of the load open or closed. Hot air defroster keeps windshield clear. Acoustical foam padding insulates against sound and weather. The deluxe six-way adjustable seat is equipped with a mechanical suspension and includes head and arm rests.

STANDARD CARRIER EQUIPMENT

CARRIER CHASSIS

Chassis is Terex designed with four-wheel drive and four-wheel steer (4X4X4). Has box-type construction with reinforcing cross members, a precision machined turn table mounting plate and integrally welded outrigger boxes. Decking has anti-skid surfaces, including between the frame rails, a lockable front tool storage compartment, and access steps and handles on the left and right sides and on all four corners. Lights are recessed into the outrigger boxes for protection. Air reservoir drains are collected in an easily accessible central location.

AXLES AND SUSPENSION

Rear axle is a planetary drive/steer type with 10.5" (0.26m) of total oscillation. Automatic oscillation lockouts engage when the superstructure is swung 10° either direction. Front axle is a planetary drive/steer type, rigidly mounted to the frame for increased stability.

CONTROLS

Armrest mounted dual axis controls for winch(s), swing, and boom elevation. Winch rotation indication incorporated into control handles. Armrest swings up to improve access and egress. Vernier adjustable hand throttle included. Steering column mounted turn signal, wiper, and shift controls. Switches include ignition, engine stop, lights, horn, roof window wiper, defroster, steering mode, parking brake, outriggers, 360° house lock, etc. Horn and winch speed shift switches are mounted in the levers. Foot control pedals include swing brake, boom telescope, service brake, and accelerator.

INSTRUMENTATION AND ACCESSORIES

In-cab gauges include air pressure, bubble level, engine oil pressure, fuel, engine temperature, voltmeter, transmission temperature, and transmission oil pressure. Indicators include low air, high water temperature, low oil pressure, high transmission temperature, and low coolant level audio/visual warning, hoist drum rotation indicator(s), and Rated Capacity Indicator. Accessories include fire extinguisher; light package including headlights, taillight, brake lights, directional signals, four-way hazard flashers, dome light, and back-up lights with audible back-up alarm; wind-shield washer/wiper; skylight wiper; R.H. and L.H. rear view mirrors; dash lights; and seat belt. Circuit breakers protect electrical circuits.

HYDRAULIC CONTROL VALVES

Valves are mounted on the rear of the upper structure and are easily accessible. Valves have electric/hydraulic operators and include one pressure compensated two spool valve for boom elevation and telescope. One pressure compensated two spool valve for main and auxiliary winch, and one single spool valve for swing. System provides for simultaneous operation of all crane functions. High pressure regeneration feature provides 2-speed boom extension. Quick disconnects are provided for ease of installation of pressure check gauges.

OPTIONAL EQUIPMENT

Auxiliary Winch • Single axis armrest mounted controllers • LP Heater/Defroster • Hydraulically powered Air Conditioner with or without hydraulic heater • Diesel Heater/Defroster • Work Lights, Rotating Beacon

STEERING

Hydraulic four-wheel full power steering for two-wheel, four-wheel coordinated, or four-wheel crab steer is easily controlled by steering wheel. A rear axle centering light is provided.

	Turning Radius: (to CL of outside tire)	Curb Clearance Radius
Two-wheel:	41' 7" (12.7 m)	43' 2" (13.2 m)
Four-wheel:	22' 10" (7.0 m)	24' 7" (7.5 m)

TRANSMISSION

Range shift type power-shift transmission with integral torque converter provides 6 speeds forward and 6 speeds reverse with neutral safety start. Four wheel drive engages automatically with low range and two wheel drive with high range. A remote mounted oil filter provides easy access. Automatic pulsating back-up alarm.





ROUGH TERRAIN CRANE RT700 SERIES

STANDARD CARRIER EQUIPMENT (CONTINUED)

MULTI-POSITION OUT & DOWN OUTRIGGERS

Fully independent hydraulic outriggers may be utilized fully extended to 24 ft. (7.32 m) centerline to centerline, in their 1/2 extended position, or fully retracted for maximum flexibility. Easily removable 24" diameter Almag floats, each with an area of 452 in² (2919 cm²), stow on the outrigger boxes at their point of use. Complete controls and a sight leveling bubble are located in the operator's cab.

WHEELS AND TIRES

Disc type wheels with full tapered bead seat rim. 157.56" (4.0 m) wheel-base.

TIRES

Wide earthmover (E3) style tread tires provide life and flotation. 29.5x25, 28 P.R. - std.

SERVICE BRAKES

Split system air over hydraulic 18.5" (470 mm) diameter disc dual caliper brakes on all wheels.

PARKING BRAKE

Electrically controlled front axle mounted spring-set, air released drum type parking brake with indicator light.

OPTIONAL EQUIPMENT

Cold Weather Starting Aid, Immersion Heater, Pintle Hook, Clearance Lights, Front Mounted Winch - 20,000 lb (9 072 kg), Independent Rear or Four Mode Rear Wheel Steer.

ENGINE SPECIFICATION

- ▶ Make and Model, Cummins QSB 6.7 (275 hp)
- ▶ Type 6 cylinder
- ▶ Displacement 409 in³ (6.7 L)
- ▶ Rated HP 275 hp (205 kw) @ 2500 rpm
- ▶ Max. Gross HP 275 hp (205 kw) @ 2300 rpm
- ▶ Max. Gross Torque 750 lb • ft (990 N•m) @ 1500 rpm
- ▶ Aspiration Turbocharged & charge air cooled
- ▶ Air filter dry type
- ▶ Electrical System 12 volt
- ▶ Alternator 102 amp
- ▶ Battery (2) 12V-1900 C.C.A.
- ▶ Fuel Capacity 80 gal (304 L)

All performance data is based on a gross vehicle weight of 94,898 lb (43 045 kg). 29.5x25 tires, 4x4 drive. Performance may vary due to engine performance. Gradeability data is theoretical and is limited by tire slip, machine stability, or oil pan design.

PERFORMANCE (STANDARD ENGINE)

Transmission Gear	Forward Drive	Max. Speed	Max. Tractive Effort	Gradeability @ Stall
▶ 1	4-wheel	2.1 mph (3.4 kph)	68,645 lb(31, 137 kg)	98.9%
▶ 2	4-wheel	4.4 mph (7.1 kph)	33,050 lb (14,991 kg)	34.8%
▶ 3	4-wheel	12.3 mph (19.8 kph)	11,7921b (5,349 kg)	10.5%
▶ 4	2-wheel	5.4 mph (8.4 kph)	27,7771b (12, 599 kg)	28.3%
▶ 5	2-wheel	10.9 mph (17.5 kph)	13, 3751b (6,067kg)	12.2%
▶ 6	2-wheel	25.0 mph (40.8 kph)	4,7681b (2,163 kg)	3%

HYDRAULIC SYSTEM

HYDRAULIC PUMPS

Three gear type pumps, one single and two in tandem, driven off the transmission. Combined system capability is 120 gpm (455 lpm). Includes pump disconnect on winch pump

- ▶ **Main and Auxiliary winch pump**
57.8 gpm (218.8lpm) @ 4,500 psi (316.4 kg/cm²)
- ▶ **Boom Hoist and Telescope Pump**
42.1 gpm (159.4 lpm) @ 4,500 psi (316.4 kg/cm²)
- ▶ **Power Steering, Outrigger and Swing Pump**
20.2 gpm (76.5lpm) @ 3,500 psi (246.1 kg/cm²)

FILTRATION

Full flow oil filtration system with bypass protection includes a removable 60 mesh (250 micron) suction screen-type filter and five micron synthetic depth type media replaceable return line filter.

HYDRAULIC RESERVOIR

All steel, welded construction with internal baffles and diffuser. Provides easy access to filters and is equipped with an external sight level gauge. The hydraulic tank is self pressurizing to aid in keeping out contaminants and in reducing potential pump cavitation. Capacity is 178 gal (674 liters). Hydraulic oil cooler is standard.

OPTIONAL HOIST LINE

Main winch and optional auxiliary winch 3/4" (19 mm) rotation resistant compacted strand 34 x 7 grade 1960. Min. breaking strength 34.5 tons (31.7 mt).

MAIN WINCH SPECIFICATIONS

Hydraulic winch with bent axis piston motor and planetary reduction gearing provides 2-speed operation with equal speeds for power up and down. Winch is equipped with an integral automatic brake, grooved drum, tapered flanges, standard cable roller on drum, and an electronic drum rotation indicator.

Performance	LO-Range	HI-Range
▶ Max line speed (no load)		
▶ First layer	191 fpm (9 m/min)	341 fpm (103.9 m/min.)
▶ Fifth layer	275 fpm (83.8 m/min)	489 fpm (149.0 m/min.)
▶ Max. line pull-first layer	18,450 lb (8 369 kg)	9,002 lb (4 083 kg)
▶ Max. line pull-fifth layer	12,845 lb (5 826 kg)	5,052 lb (2 846 kg)
▶ Permissible line pull	13,800 lb (6 260 kg)	

- ▶ **Drum Dimensions**
- ▶ 13" (330 mm) drum diameter
- ▶ 20.16" (512 mm) length
- ▶ 12.5" (546 mm) flange dia.
- ▶ Cable: 3/4" x 600' (19 mm x 182.9 m)
- ▶ Cable type: 3/4" (19 mm) 6 x 19 IWRC XIPS, right regular lay, performed.
- ▶ Min. breaking strength 29.4 tons (26.6 mt)

- ▶ **Drum Capacity**
- ▶ Max. Storage: 561' (171 m)
- ▶ Max. useable: 561' (171 m)*

*Based on minimum flange height above top layer to comply with ANSI B30.5

OPTIONAL AUXILIARY WINCH

Hydraulic two-speed winch with bent axis piston motor, equal speed power up and down, planetary reduction with integral automatic brake, grooved drum with tapered flanges, drum roller, and rotation indicator.

Performance	
▶ Max. line speed (no load)	Fifth layer 489 fpm (149.0 m/min)
▶ Max. line pull First layer	18,450 lb (8 369 kg)
▶ Drum Dimensions and Capacity	(Same as main winch)





ROUGH TERRAIN CRANE RT700 SERIES

GENERAL DIMENSIONS

- Dimensions given assume the boom is fully retracted in travel position and 29.50 x 25 tires.
- Minimum ground clearance under: transmission-29.00", axle bowls-23.62", tie rods-23.88"
- Track Width: 8ft - 7in (2.6 m).
- Width of Carrier: 9ft - 10in (3.0 m)
- Tire to Frame Angle
 - Approach Angle: 19°
 - Departure Angle: 18°

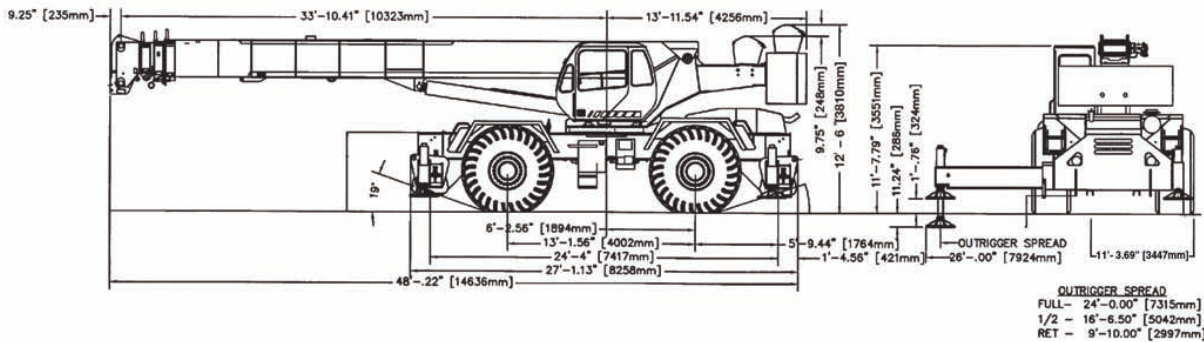

WEIGHTS & AXLE LOADS	GROSS WEIGHT LB	UPPER FACING FRONT		GROSS WEIGHT KG	UPPER FACING FRONT	
		FRONT	REAR		FRONT	REAR
Basic Crane with 15,200 lb (6 895 kg) Counterweight	+ 91,216	+ 47,047	+ 44,169	+ 41,372	+ 21,338	+ 20,033
Add Options:						
32' (9.8 m) Swing-on jib (Stowed)	+ 1,270	+ 2,524	- 354	+ 576	+ 1,145	- 161
33'-57"(10.1-17.4 m)	+ 2,170	+ 3,992	- 1,822	+ 984	+ 1,811	- 826
Swing-on Jib (Stowed)						
Auxiliary Boom Head	+ 125	+ 406	- 281	+ 57	+ 184	- 127
Auxiliary Winch with 600' of 6x19 class Wire Rope	+ 134	- 35	+ 159	+ 61	- 16	+ 72
75T (68.0 mt) 5-Sheave Hook Block	+ 1,608	+ 3,447	- 1,839	+ 729	+ 1,563	- 834
60T (54.4 mt) 5-Sheave Hook Block	+ 1,204	+ 2,581	- 1,377	+ 546	+ 1,171	- 625
20T (18.1 mt) 1-Sheave Hook Block	+ 570	+ 936	- 366	+ 259	+ 425	- 166
12T (10.9 mt) Hook and Ball (In tool box)	+ 419	+ 426	- 7	+ 190	+ 193	- 3
Pintle Hook: Front:	+ 45	+ 60	- 15	+ 20	+ 27	- 7
Rear:	+ 45	- 25	+ 70	+ 20	- 11	+ 32
Substitute:						
600' of 34x7 class spin resistant wire rope	+ 96	- 30	+ 126	+ 44	- 14	+ 57

Note: Weights are for Terex supplied equipment and are subject to 2% variation due to manufacturing tolerances.

TEREX Cranes
 106-12th Street S.E.
 Waverly, Iowa 50677-9466 USA

TEL (319) 352-3920 FAX (319) 352-5727
 EMAIL inquire@terexwaverly.com
 WEB terex-cranes.com

Disclaimer: Effective Date: March, 2008. Product specifications and prices are subject to change without notice or obligation. The photographs and/or drawings in this document are for illustrative purposes only. Refer to the appropriate Operator's Manual for instructions on the proper use of this equipment. Failure to follow the appropriate Operator's Manual when using our equipment or to otherwise act irresponsibly may result in serious injury or death. The only warranty applicable to our equipment is the standard written warranty applicable to the particular product and sale and Terex makes no other warranty, express or implied. Products and services listed may be trademarks, service marks or trade-names of Terex Corporation and/or its subsidiaries in the USA and other countries.

All rights are reserved. Terex® is a registered trademark of Terex Corporation in the USA and many other countries.
 Copyright 2008 Terex Corporation.

PRINTED IN U.S

January 22, 2009
 P/N: RT700SPEC





Range Diagram and Lifting Capacity | RT780

80 TON LIFTING CAPACITY

RANGE DIAGRAM 40' - 126' BOOM

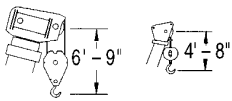

Dimensions are for largest factory furnished hook block and hook & ball, with anti-two block activated

COUNTER WEIGHT	W/AUX. WINCH 13,660 LB W/O AUX. WINCH 15,200 LB
BOOM LENGTH	40'-126'
OUTRIGGER SPREAD	24'
STABILITY PERCENTAGE	ON OUTRIGGERS 85% ON TIRES 75%
PCSA CLASS	10-316

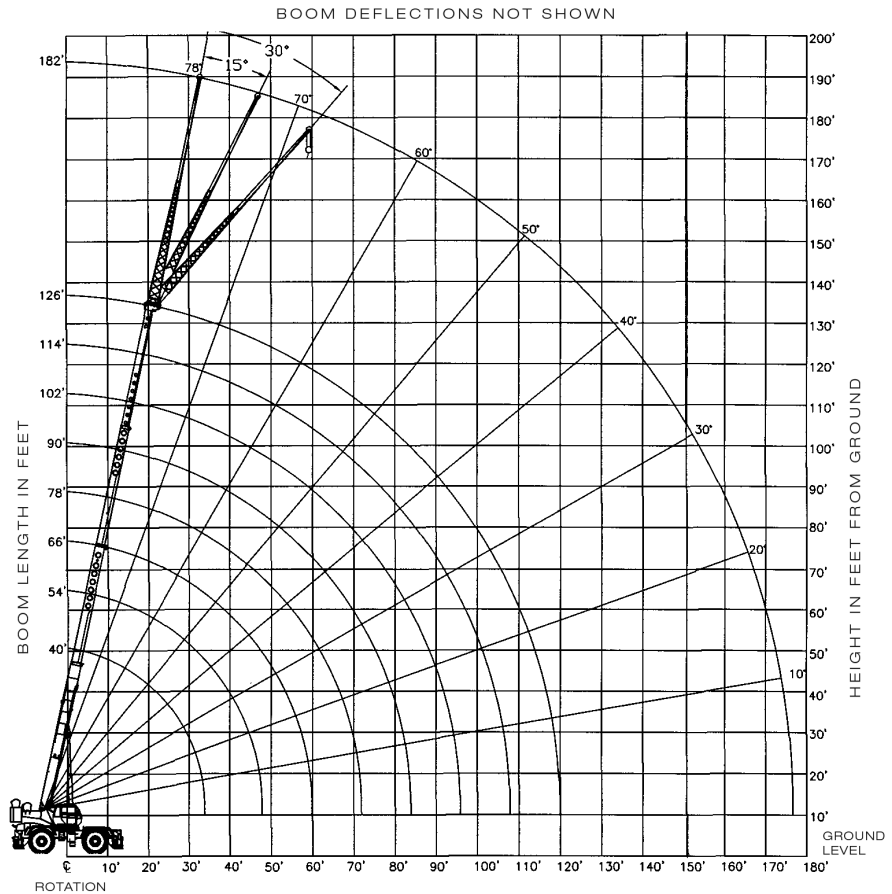

CRANE WORKING CONDITIONS

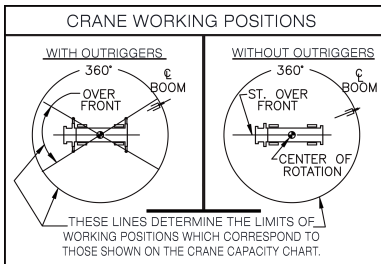

REDUCTION IN MAIN BOOM CAPACITY

All jib in stowed position	0 lb
Aux. boom in head sheave	100lb

HOOK BLOCK WEIGHTS

Hook and ball	419 lb
Hook block (5 sheave)	1608 lb





ROUGH TERRAIN CRANE
RT780

LIFTING CAPACITIES CAUTION: Do not use this specification sheet as a load rating chart. The format of data is not consistent with the machine chart and may be subject to change

ON OUTRIGGERS - FULLY EXTENDED AND WITH 15,200 LB COUNTERWEIGHT

LOAD RADIUS (FT)	BOOM LENGTH 40'			BOOM LENGTH 54'			BOOM LENGTH 66'			BOOM LENGTH 78'			LOAD RADIUS (FT)
	LOADED ANGLE (DEG) REF.	OVER FRONT (LB)	360° (LB)	LOADED ANGLE (DEG) REF.	OVER FRONT (LB)	360° (LB)	LOADED ANGLE (DEG) REF.	OVER FRONT (LB)	360° (LB)	LOADED ANGLE (DEG) REF.	OVER FRONT (LB)	360° (LB)	
10	69.4	160,000*	160,000*	75.0	102,600*	102,600*							10
12	66.2	125,700*	125,700*	72.8	102,600*	102,600*							12
15	61.3	108,900*	108,900*	69.3	100,600*	100,600*	73.3	80,700*	80,700*				15
20	52.3	84,800*	84,800*	63.4	85,400*	85,400*	68.6	72,000*	72,000*	72.1	62,300*	62,300*	20
25	42.0	65,700*	65,700*	57.1	66,800*	66,800*	63.8	64,900*	64,900*	68.1	55,800*	55,800*	25
30	28.5	52,900*	49,300	50.3	54,000*	50,600	58.7	54,500*	51,100	64.0	49,800*	49,800*	30
35	**			42.6	40,600	37,800	53.3	41,100	38,300	59.8	41,300	38,600	35
40				33.6	31,600	29,500	47.5	32,100	30,000	55.3	32,400	30,300	40
45				21.0	25,300	23,600	41.1	26,000	24,200	50.6	26,200	24,500	45
50				**			33.6	21,300	19,900	45.5	21,700	20,300	50
55							24.0	17,800	16,500	39.9	18,200	17,000	55
60							**			33.6	15,400	14,300	60
65										25.8	13,100	12,200	65
70										14.2	11,200	10,400	70
75										**			75

****MAXIMUM CAPACITY AT 0 DEGREE BOOM ANGLE**

BOOM LOAD RADIUS (FT)	BOOM LENGTH 40'		BOOM LENGTH 54'			BOOM LENGTH 66'			BOOM LENGTH 78'		
	OVER FRONT (LB)	360° (LB)	BOOM LOAD RADIUS (FT)	OVER FRONT (LB)	360° (LB)	BOOM LOAD RADIUS (FT)	OVER FRONT (LB)	360° (LB)	BOOM LOAD RADIUS (FT)	OVER FRONT (LB)	360° (LB)
33.9	28,600*	28,800*	47.9	19,100*	19,100*	59.9	14,200*	13,900	71.9	10,500	9,700

USE THESE CHARTS ONLY WHEN ALL OUTRIGGERS ARE FULLY EXTENDED

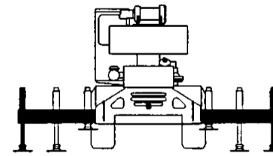

ON OUTRIGGERS - FULLY EXTENDED AND WITH 15,200 LB COUNTER WEIGHT

LOAD RADIUS (FT)	BOOM LENGTH 90'			BOOM LENGTH 102'			BOOM LENGTH 114'			BOOM LENGTH 126'			RADIUS (FT)
	BOOM ANGLE (DEG) REF.	OVER FRONT (LB)	360° (LB)	BOOM ANGLE (DEG) REF.	OVER FRONT (LB)	360° (LB)	BOOM ANGLE (DEG) REF.	OVER FRONT (LB)	360° (LB)	BOOM ANGLE (DEG) REF.	OVER FRONT (LB)	LOAD 360° (LB)	
20	74.6	56,300*	56,300*										20
25	71.2	48,100*	48,100*	73.5	42,000*	42,000*							25
30	67.7	41,800*	41,800*	70.5	36,500*	36,500*	72.6	31,600*	31,600*				30
35	64.2	36,700*	36,700*	67.5	32,200*	32,200*	70.0	29,600*	29,600*	72.0	24,800*	24,800*	35
40	60.6	32,600	30,500	64.3	28,700*	28,700*	67.2	26,300*	26,300*	69.5	24,700*	24,700*	40
45	56.8	26,400	24,700	61.1	25,800*	24,800	64.5	23,600*	23,600*	67.1	22,200*	22,200*	45
50	52.8	21,900	20,400	57.8	22,000	20,600	61.6	21,500*	20,700	64.5	20,100*	20,100*	50
55	48.6	18,400	17,200	54.4	18,500	17,300	58.7	18,600	17,400	62.0	18,300*	17,500	55
60	44.1	15,600	14,600	50.8	15,700	14,700	55.6	15,800	14,800	59.3	15,900	14,900	60
65	39.1	13,300	12,400	47.0	13,500	12,600	52.5	13,600	12,700	56.6	13,700	12,800	65
70	33.6	11,500	10,700	42.9	11,600	10,900	49.2	11,700	11,000	53.8	11,800	11,000	70
75	27.0	9,900	9,100	38.5	10,100	9,300	45.7	10,200	9,500	50.9	10,300	9,500	75
80	18.2	8,500	7,800	33.6	8,700	8,000	42.0	8,900	8,200	47.8	8,900	8,300	80
85	**			27.9	7,500	6,900	38.0	7,700	7,000	44.6	7,800	7,200	85
90				20.7	6,500	5,900	33.6	6,700	6,100	41.2	6,800	6,200	90
95				8.8	5,600	5,000	28.5	5,800	5,200	37.6	5,900	5,300	95
100				**			22.5	5,000	4,400	33.6	5,100	4,500	100
105							13.9	4,200	3,700	29.1	4,400	3,800	105
110							**			23.8	3,700	3,200	110
115										16.9	3,200	2,600	115

****MAXIMUM CAPACITY AT 0 DEGREE BOOM ANGLE**

BOOM LOAD RADIUS (FT)	BOOM LENGTH 90'		BOOM LENGTH 102'			BOOM LENGTH 114'			BOOM LENGTH 126'		
	OVER FRONT (LB)	360° (LB)	BOOM LOAD RADIUS (FT)	OVER FRONT (LB)	360° (LB)	BOOM LOAD RADIUS (FT)	OVER FRONT (LB)	360° (LB)	BOOM LOAD RADIUS (FT)	OVER FRONT (LB)	360° (LB)
83.9	7,500	6,900	95.9	5,400	4,800	107.9	3,800	3,300	119.9	2,600	2,100





ROUGH TERRAIN CRANE

RT780

LIFTING CAPACITIES

CAUTION: Do not use this specification sheet as a load rating chart. The format of data is not consistent with the machine chart and may be subject to change

ON OUTRIGGERS - RETRACTED AND WITH 15,200 LB COUNTERWEIGHT

LOAD RADIUS (FT)	BOOM LENGTH 40'		BOOM LENGTH 54'		BOOM LENGTH 66'		BOOM LENGTH 78'		LOAD RADIUS (FT)
	BOOM ANGLE (DEG)	360° (LB)	BOOM ANGLE (DEG)	360° (LB)	BOOM ANGLE (DEG)	360° (LB)	BOOM ANGLE (DEG)	360° (LB)	
	REF.		REF.		REF.		REF.		
10	69.4	84,600	75.0	85,700					10
12	66.2	59,400	72.8	60,400					12
15	61.3	39,400	69.3	40,500	73.3	40,900			15
20	52.3	23,300	63.4	24,400	68.6	24,900	72.1	25,100	20
25	42.0	15,000	57.1	16,100	63.8	16,600	68.1	16,900	25
30	28.5	9,900	50.3	11,000	58.7	11,500	64.0	11,900	30
35	**		42.6	7,600	53.3	8,100	59.8	8,500	35
40			33.6	5,100	47.7	5,700	55.3	6,000	40
45			21.D	3,300	41.1	3,800	50.6	4,100	45
50									50
55									55

USE THESE CHARTS ONLY WHEN ALL OUTRIGGERS ARE PINNED IN MID POSITION

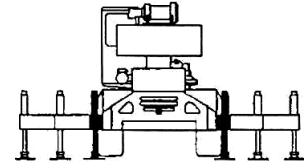

****MAXIMUM CAPACITY AT 0 DEGREE BOOM ANGLE**

BOOM LENGTH 40'		BOOM LENGTH 54'		BOOM LENGTH 66'		BOOM LENGTH 78'	
LOAD RADIUS (FT)	360° (LB)	LOAD RADIUS (FT)	360° (LB)	LOAD RADIUS (FT)	360° (LB)	LOAD RADIUS (FT)	360° (LB)
33.9	7,000						

ON OUTRIGGERS - RETRACTED AND WITH 15,200 LB COUNTERWEIGHT

LOAD RADIUS (FT)	BOOM LENGTH 90'		BOOM LENGTH 102'		BOOM LENGTH 114'		BOOM LENGTH 126'		LOAD RADIUS (FT)
	BOOM ANGLE (DEG)	360° (LB)	BOOM ANGLE (DEG)	360° (LB)	BOOM ANGLE (DEG)	360° (LB)	BOOM ANGLE (DEG)	360° (LB)	
	REF.		REF.		REF.		REF.		
10									10
12									12
15									15
20	74.6	25,300							20
25	71.2	17,100	73.5	17,100					25
30	67.7	12,100	70.5	12,100	72.6	12,200			30
35	64.2	8,700	67.5	8,700	70.0	8,900	72.0	9,000	35
40	60.6	6,200	64.3	6,200	67.2	6,400	69.5	6,600	40
45	56.8	4,400	61.1	4,400	64.5	4,600	67.1	4,800	45
50					61.6	3,100	64.5	3,400	50
55									55





ROUGH TERRAIN CRANE RT780

LIFTING CAPACITIES

CAUTION: Do not use this specification sheet as a load rating chart. The format of data is not consistent with the machine chart and may be subject to change

ON OUTRIGGERS - MID POSITION AND WITH 15,200 LB COUNTERWEIGHT

LOAD RADIUS (FT)	BOOM LENGTH 40'		BOOM LENGTH 54'		BOOM LENGTH 66'		BOOM LENGTH 78'		LOAD RADIUS (FT)
	BOOM ANGLE (DEG) REF.	360° (LB)	BOOM ANGLE (DEG) REF.	360° (LB)	BOOM ANGLE (DEG) REF.	360° (LB)	BOOM ANGLE (DEG) REF.	360° (LB)	
10	69.4	150,000*	75.0	102,600*					10
12	66.2	125,700*	72.8	102,600*					12
15	63.1	103,100	69.3	100,600*	73.3	80,700*			15
20	52.3	55,100	63.4	56,200	68.6	56,700	72.1	57,000	20
25	42.0	35,600	57.1	36,800	63.8	37,300	68.1	37,500	25
30	28.5	25,000	50.3	26,300	58.7	26,800	64.0	27,000	30
35	**		42.6	19,600	53.3	20,200	59.8	20,500	35
40			33.6	15,000	47.5	15,600	55.3	16,000	40
45			21.0	11,700	41.1	12,200	50.6	12,600	45
50			**		33.6	9,700	45.5	10,100	50
55					24.0	7,700	39.9	8,100	55
60					**		33.6	6,400	60
65							25.8	5,100	65
70							14.2	3,900	70
75							**		75

USE THESE CHARTS ONLY WHEN ALL OUTRIGGERS ARE PINNED IN MID POSITION

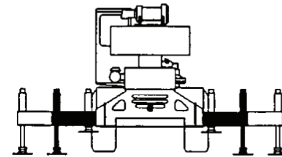

**MAXIMUM CAPACITY AT 0 DEGREE BOOM ANGLE

BOOM LENGTH 40'		BOOM LENGTH 54'		BOOM LENGTH 66'		BOOM LENGTH 78'	
LOAD RADIUS (FT)	360° (LB)	LOAD RADIUS (FT)	360° (LB)	LOAD RADIUS (FT)	360° (LB)	LOAD RADIUS (FT)	360° (LB)
33.9	19,500	47.9	10,000	59.9	6,000	71.9	3,500

ON OUTRIGGERS - MID POSITION AND WITH 15,200 LB COUNTERWEIGHT

LOAD RADIUS (FT)	BOOM LENGTH 90'		BOOM LENGTH 102'		BOOM LENGTH 114'		BOOM LENGTH 126'		LOAD RADIUS (FT)
	BOOM ANGLE (DEG) REF.	360° (LB)	BOOM ANGLE (DEG) REF.	360° (LB)	BOOM ANGLE (DEG) REF.	360° (LB)	BOOM ANGLE (DEG) REF.	360° (LB)	
20	74.6	56,300*							20
25	71.2	37,800	73.5	37,900					25
30	67.7	27,200	70.5	27,400	72.6	27,500			30
35	64.2	20,600	67.5	20,800	70.0	20,900	72.0	21,000	35
40	60.6	16,100	64.3	16,300	67.2	16,400	69.5	16,400	40
45	56.8	12,800	61.1	13,000	64.5	13,100	67.1	13,100	45
50	52.8	10,300	57.8	10,500	61.6	10,600	64.5	10,600	50
55	48.6	8,300	54.4	8,500	58.7	8,600	62.0	8,700	55
60	44.1	6,700	50.8	6,900	55.6	7,000	59.3	7,100	60
65	39.1	5,300	47.0	5,500	52.5	5,700	56.6	5,800	65
70	33.6	4,200	42.9	4,400	49.2	4,600	53.8	4,700	70
75	27.0	3,300	38.5	3,500	45.7	3,600	50.9	3,700	75
80			33.6	2,600	42.0	2,800	47.8	2,900	80





ROUGH TERRAIN CRANE
RT780

LIFTING CAPACITIES **CAUTION:** Do not use this specification sheet as a load rating chart. The format of data is not consistent with the machine chart and may be subject to change

SIDE STOW JIB ON FULLY EXTENDED OUTRIGGERS AND

LOADED BOOM ANGLE (DEG)	32' OFFSETTABLE JIB/NO PULL OUT INSTALLED									33' OFFSETTABLE JIB/PULL OUT RETRACTED									LOADED BOOM ANGLE (DEG)
	0° OFFSET			15° OFFSET			30° OFFSET			0° OFFSET			15° OFFSET			30° OFFSET			
	(REF) RADIUS (FT)	FRONT ONLY (LB)	360° (LB)	(REF) RADIUS (FT)	FRONT ONLY (LB)	360° (LB)	(REF) RADIUS (FT)	FRONT ONLY (LB)	360° (LB)	(REF) RADIUS (FT)	FRONT ONLY (LB)	360° (LB)	(REF) RADIUS (FT)	FRONT ONLY (LB)	360° (LB)	(REF) RADIUS (FT)	FRONT ONLY (LB)	360° (LB)	
77	41	12,600*	12,600	50	8,500*	8,500*	57	6,600*	6,600*	41	12,600*	12,600*	50	8,600*	8,600*	57	6,500*	6,500*	77
75	46	11,900*	11,900	55	8,200*	8,200*	61	6,400*	6,400*	47	12,100*	12,100*	56	8,200*	8,200*	62	6,300*	6,300*	75
73	51	11,300*	11,300	60	7,800*	7,800*	66	6,300*	6,300*	52	11,600*	11,600*	61	7,900*	7,900*	67	6,200*	6,200*	73
71	57	10,400*	10,400	66	7,400*	7,400*	71	6,000*	6,000*	58	11,000*	11,000*	67	7,600*	7,600*	72	6,000*	6,000*	71
68	65	9,600*	9,600*	73	7,100*	7,100*	78	5,900*	5,900*	66	10,000*	10,000*	74	7,200*	7,200*	79	6,000*	6,000*	68
65	73	8,900*	8,900*	80	6,800*	6,800*	85	5,700*	5,700*	74	9,300*	9,300*	81	6,800*	6,800*	86	5,700*	5,700*	65
62	80	8,300*	8,300*	87	6,500*	6,500*	92	5,500*	5,500*	81	9,000*	8,700*	88	6,500*	6,500*	93	5,500*	5,500*	62
59	87	7,700*	7,700*	94	6,200*	6,200*	98	5,300*	5,300*	88	7,700*	7,400*	95	6,300*	6,300*	99	5,400*	5,400*	59
55	96	7,000*	6,600	102	5,900*	5,900*	106	5,200*	5,200*	97	6,300	5,800	103	5,800	5,300	107	5,300*	5,300	55
51	104	5,800	5,400	110	5,500	5,100	113	5,000*	5,000*	105	5,100	4,600	111	4,800	4,300	114	4,400	4,400	51
47	112	4,800	4,400	116	4,600	4,200	119	4,300	4,300	113	4,100	3,700	117	3,900	3,500	120	3,600	3,600	47
43	119	4,100	3,700	123	3,900	3,500	125	3,600	3,600	120	3,300	3,000	124	3,200	2,800	126	2,900	2,900	43
38	126	3,300	3,000	130	3,100	2,900	131	3,000	2,700	127	2,600	2,300	131	2,400	2,100	132	2,300	2,000	38
32	134	2,700	2,300	137	2,500	2,200	137	2,400	1,900	135	2,000	1,700	138	1,800	1,500	138	1,700	1,200	32
25	141	2,100	1,700	142	2,000	1,700				143	1,400		144	1,300					25

SIDE STOW JIB ON FULLY EXTENDED OUTRIGGERS AND WITH 15,200 LB COUNTERWEIGHT

LOADED BOOM ANGLE (DEG)	57' OFFSETTABLE JIB									LOADED BOOM ANGLE (DEG)
	0° OFFSET			15° OFFSET			30° OFFSET			
	LOAD RADIUS (REF) (FT)	FRONT ONLY (LB)	360° (LB)	LOAD RADIUS (REF) (FT)	FRONT ONLY (LB)	360° (LB)	LOAD RADIUS (REF) (FT)	FRONT ONLY (LB)	360° (LB)	
77	48	6,600*	6,600*	66	4,600*	4,600*	75	3,400*	3,400*	77
75	56	6,500*	6,500*	72	4,400*	4,400*	81	3,300*	3,300*	75
73	63	6,300*	6,300*	77	4,200*	4,200*	87	3,200*	3,200*	73
71	70	6,100*	6,100*	83	4,000*	4,000*	92	3,100*	3,100*	71
68	80	5,500*	5,500*	91	3,800*	3,800*	100	3,000*	3,000*	68
65	90	5,000*	5,000*	99	3,600*	3,600*	108	2,900*	2,900*	65
62	98	4,600*	4,600*	106	3,400*	3,400*	115	2,800*	2,800*	62
59	106	4,300*	4,300*	114	3,200*	3,200*	121	2,700*	2,700*	59
55	116	3,900*	3,900*	123	3,000*	3,000*	129	2,600*	2,600*	55
51	125	3,600*	3,600*	132	2,900*	2,900*	137	2,600*	2,600*	51
47	133	3,000	2,900	140	2,800*	2,700	143	2,500*	2,500*	47
43	140	2,500	2,300	147	2,400	2,200	149	2,400	2,100	43
38	148	1,900	1,700	154	1,800	1,600	155	1,800	1,600	38
32	157	1,400	1,100	161	1,300	1,100	162	1,300	1,100	32
25	165	900								25

Notes For Jib Capacities:

- A. For all boom lengths less than the maximum with a jib erected, the rated loads are determined by boom angle only in the appropriate column.
- B. For boom angle not shown, use the capacity of the next lower boom angle.
- C. Listed radii are for fully extended main boom only.

ON TIRES

RADIUS (FT)	MAX BOOM LENGTH (FT)	29.5 X 25 28 PR			
		STATIONARY		PICK & CARRY	
		360°	STRAIGHT OVER FRONT	STATIONARY	CREEP
10	40	48,000	74,100*	56,100*	47,100*
12	40	40,600	65,200*	49,100*	41,000*
15	40	30,100	54,300	40,900*	34,000*
20	40	20,200	36,100	31,400*	25,700*
25	54	13,800	25,000	24,800*	20,000*
30	54	9,400	18,300	18,300	15,700*
35	54	6,700	14,300	14,300	13,900*
40	66	5,000	11,700	11,700	11,200*
45	66	3,500	9,700	9,700	9,100*
50	66	2,400	8,000	8,000	8,000
55	78	1,600	6,400	6,400	6,400
60	78		5,000	5,000	5,000
65	78		3,400	3,400	3,400
70	90		3,200	3,200	3,200
75	90		2,800	2,800	2,800
80	90		2,300	2,300	2,300

Notes For On Tire Capacities:

- A. For Pick and Carry operations, boom must be centered over the front of the crane with swing brake and lock engaged. Use minimum boom point height and keep load close to ground surface.
- B. The load should be restrained from swinging. NO ON TIRE OPERATION WITH JIB ERECTED.
- C. Without outriggers, never maneuver the boom beyond listed load radii for applicable tires to ensure stability.
- D. Creep speed is crane movement of less than 200' (61m) in a 30 minute period and not exceeding 1.0 mph (1.6 km/h).
- E. Refer to General Notes for additional information.

RECOMMENDED TIRE PRESSURE

TIRE SIZE	STATIONARY	CREEP	2 1/2 MPH	TRAVEL
29.5 x 25-28 PR	62 PSI	62 PSI	62 PSI	54 PSI

MAXIMUM PERMISSIBLE HOIST LINE LOAD

LINE PARTS	1	2	3	4	5	6	7	8	9	10	11
MAIN & AUX. HOIST	13,800	27,600	41,400	55,200	69,000	82,800	96,600	110,400	124,200	138,000	150,000
WIRE ROPE	3/4" ROTATION RESISTANT 34 X 7 COMPACTED STRAND, GRADE 2160, MINIMUM BREAKING STRENGTH - 34.5 TONS. WEIGHT 1.24 LB/FT 3/4" 6X19 OR 6X37, IPS, IWRC, PERFORMED RIGHT REGULAR LAY MINIMUM BREAKING STRENGTH - 25.6 TONS. WEIGHT 1.04 LB/FT										





ROUGH TERRAIN CRANE

RT780

ROUGH TERRAIN CRANE RT780 | Notes



**TEREX®****General Notes | RT780****GENERAL**

1. Rated loads as shown on Lift Charts pertain to this machine as originally manufactured and equipped. Modifications to the machine or use of optional equipment or other than that specified can result in a reduction of capacity.
2. Construction equipment can be hazardous if improperly operated or maintained. Operation and maintenance of this machine shall be in compliance with the information in the Operator's, Parts and Safety Manuals supplied with this machine. If These manuals are missing, order replacements from the manufacturer through your distributor.
3. These warnings do not constitute all of the operating conditions for the crane. The operator and job site supervision must read the OPERATORS MANUAL, CIMA SAFETY MANUAL, APPLICABLE OSHA REGULATIONS, AND SOCIETY OF MECHANICAL ENGINEERS (ASME) SAFETY STANDINGS FOR CRANES.
4. This crane and its load ratings are in accordance with POWER CRANE & SHOVEL ASSOCIATION, STANDARD NO.4 SAE CRANE LOAD STABILITY TEST CODE J765A, SAE METHOD OF TEST FOR CRANE STRUCTURE J1063 AND APPLICABLE SAFETY CODE FOR CRANES, DERRICKS AND HOISTS, ASME/ANSI B30.5

DEFINITIONS

1. **LOAD RADIUS** - The horizontal distance from the axis of rotation before loading to the center of the vertical hoist line or tackle with a load applied.
2. **LOADED BOOM ANGLE** - It is the angle between the boom base section and the horizontal, after lifting the rated load at the rated radius. The boom angle before loading should be greater to account for deflections. The loaded boom angle combined with boom length give only an approximation of the operating radius.
3. **WORKING AREA** - Areas measured in a circular arc about the centerline of rotation as shown in the diagram.
4. **FREELY SUSPENDED LOAD** - Load hanging free with no direct external force applied except by the hoist rope.
5. **SIDE LOAD** - Horizontal force applied to the lifted load either on the ground or in the air.
6. **NO LOAD STABILITY LIMIT** - The stability limit radius shown on the range diagrams is the radius beyond which it is not permitted to position the boom, when the boom angle is less than the minimum shown on the applicable load chart, because the machine can overturn without any load.
7. **BOOM SIDE OF CRANE** - The side of the crane over which the boom is positioned when in OVER SIDE working position.

SET-UP

1. Crane load ratings are based on the crane being leveled and standing on a firm, uniform supporting surface.
2. Crane load ratings on outriggers are based on all outrigger beams being fully extended or in the case of partial extension ratings mechanically pinned in the appropriate position, and the tires free of the supporting surface.
3. Crane load ratings on tires depend on appropriate inflation pressure and the tire conditions. Caution must be exercised when increasing air pressures in tires. Consult Operator's Manual for precautions.
4. Use of jibs, lattice-type boom extensions, or fourth section pullouts extended is not permitted for pick and carry operations.
5. Consult appropriate section of the Operator's and Service Manual for more exact description of hoist line reeving.
6. The use of more parts of line than required by the load may result in having insufficient rope to allow the hook block to reach the ground.
7. Properly maintained wire rope is essential for safe crane operation. Consult Operator's Manual for proper maintenance and inspection requirements.
8. When spin-resistant wire rope is used, the allowable rope loading shall be the breaking strength divided by five (5), unless otherwise specified by the wire rope manufacturer.
9. Do not elevate the boom above 60° unless the boom is positioned in-line with the crane's chassis or the outrigger are extended. Failure to observe this warning may result in loss of stability.

OPERATION

1. **CRANE LOAD RATINGS MUST NOT BE EXCEEDED. DO NOT ATTEMPT TO TIP THE CRANE TO DETERMINE ALLOWABLE LOADS.**
2. When either radius or boom length, or both, are between listed values, the smaller of the two listed load ratings shall be used.
3. Do not operate at longer radii than those listed on the applicable load rating chart (cross hatched areas shown on range diagrams.)
4. The boom angles shown on the Capacity Chart give an approximation of the operating radius for a specified boom length. The boom angle, before loading, should be greater to account for boom deflection. It may be necessary to retract the boom if maximum boom angle is insufficient to maintain rated radius.
5. Power telescoping boom sections must be extended equally.
6. Rated loads include the weight of hook block, slings, and auxiliary lifting devices. Their weights shall be subtracted from the listed rated load to obtain the net load that can be lifted. When lifting over the jib the weight of any hook block, slings, and auxiliary lifting devices at the boom head must be added to the load. When jibs are erected but unused add two (2) times the weight of any hook block, slings, and auxiliary lifting devices at the jib head to the load.
7. Rated loads do not exceed 85% on outriggers or 75% on tires, of the tipping load as determined by SAE Crane Stability Test Code J765a. Structural strength ratings in chart are indicated with an asterisk (*).
8. Rated loads are based on freely suspended loads. No attempt shall be made to drag a load horizontally on the ground in any direction.
9. The user shall operate at reduced ratings to allow for adverse job conditions, such as: soft or uneven ground, out of level conditions, high winds, side loads, pendulum action, jerking or sudden stopping of loads, hazardous conditions, experience of personnel, two machine lifts, traveling with loads, electric wires, etc. (side pull on boom or jib is hazardous). Derating of the cranes lifting capacity is required when wind speed exceeds 20 MPH. The center of the lifted load must never be allowed to move more than 3" off the center line of the base boom section due to the effects of wind, inertia, or any combination of the two.
**"Use 2" off the center line of the base boom for a two section boom, 3" for a three section boom, or 4" for a four section boom."
10. The maximum load which can be telescoped is not definable, because of variations in loadings and crane maintenance, but it is permissible to attempt retraction and extension if load ratings are not exceeded.
11. Load ratings are dependent upon the crane being maintained according to manufacturer's specifications.
12. It is recommended that load handling devices, including hooks, and hook blocks, be kept away from boom head at all times.
13. **FOR TRUCK CRANES ONLY:** 360° capacities apply only to machines equipped with a front outrigger jack and all five(5) outrigger jacks properly set. If the front (5th) outrigger jack is not properly set, the work area is restricted to the over side and over rear areas as shown on the Crane Working Positions diagram. Use the 360° load ratings in the overside work areas.
14. Do not lift with outrigger beams positioned between the fully extended and intermediate (pinned) positions.
15. Truck Cranes not equipped with equalizing (bogie) beams between the rear axles may not be used for lifting "on tires". Truck Cranes equipped with equalizing beams and rear air suspension should "dump" the air before lifting "on tires".

CLAMSHELL, MAGNET, AND CONCRETE BUCKET SERVICE

1. Maximum boom length for clamshell and magnet service is 50'.
2. Weight of clamshell or magnet, plus contents are not to exceed 6,000 lb or 90% of rated lifting capacities, whichever is less. For concrete bucket operation, weight of bucket and load must not exceed 90% of rated lifting capacity.

TEREX Cranes
106-12th Street S.E.
Waverly, Iowa 50677-9466 USA

TEL (319) 352-3920 FAX (319) 352-5727
EMAIL inquire@terexwaverly.com
WEB terex-cranes.com

Disclaimer: Effective Date: March, 2008. Product specifications and prices are subject to change without notice or obligation. The photographs and/or drawings in this document are for illustrative purposes only. Refer to the appropriate Operator's Manual for instructions on the proper use of this equipment. Failure to follow the appropriate Operator's Manual when using our equipment or to otherwise act irresponsibly may result in serious injury or death. The only warranty applicable to our equipment is the standard written warranty applicable to the particular product and sale and Terex makes no other warranty, express or implied. Products and services listed may be trademarks, service marks or trade-names of Terex Corporation and/or its subsidiaries in the USA and other countries.

All rights are reserved. Terex® is a registered trademark of Terex Corporation in the USA and many other countries.
Copyright 2008 Terex Corporation.

PRINTED IN U.S.

JULY 15, 2008

P/N: RT780RDC

