

OAH Overall Height  
 CT Cab to Tandem  
 CA Cab to Axle  
 WB Wheel Base  
 OAL Overall Length  
 BBC Bumper to Back of Cab  
 AF Afterframe

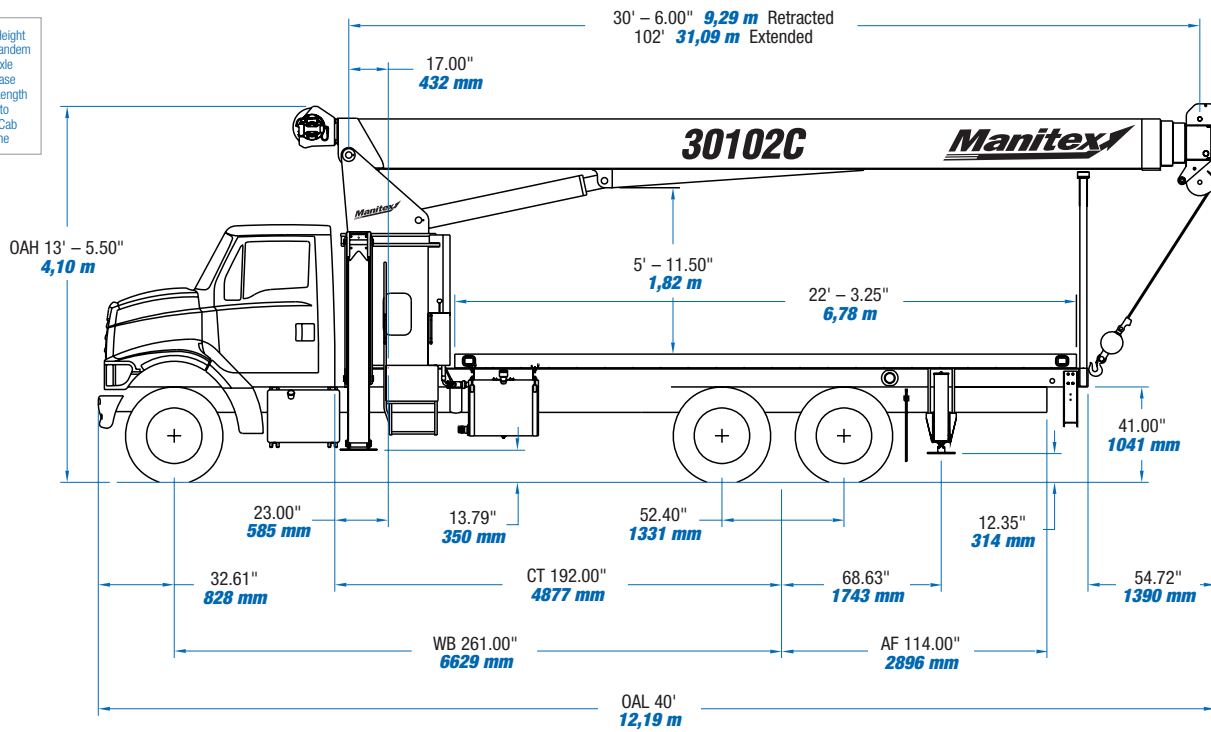

CHASSIS DATA	30102C
Wheelbase (WB)	<b>253"</b> <b>6 426 mm</b>
Cab to Tandem (CT)	<b>184"</b> <b>4 673 mm</b>
After Frame (AF)	<b>114"</b> <b>2 895 mm</b>
Frame Section Modulus at 180° Area of Operation	<b>30.0 in³</b> <b>110,000 psi</b> <b>758 422 kPa</b>
Frame Section Modulus at 360° of Operation	<b>30.0 in³</b> <b>110,000 psi</b> <b>758 422 kPa</b>
Front Axle Gross Weight Rating	<b>18,000 lb</b> <b>8 181 kg</b>
Rear Axle Gross Weight Rating	<b>34,000 lb</b> <b>15 422 kg</b>
Minimum Truck Axle Weight - Front**	<b>8,400 lb</b> <b>3 818 kg</b>
Minimum Truck Axle Weight - Back**	<b>8,400 lb</b> <b>3 818 kg</b>
Nominal Frame Width	<b>34"</b> <b>864 mm</b>

\*Frame section modulus at 360P area of operation requires front bumper stabilizer.  
 \*\*Minimum chassis weight is required to meet 85% stability requirements.  
 Chassis data is general - not for engineering. Some dimensions depend on truck selection.

MAXIMUM TIP HEIGHT	30102C
Configuration	<b>Boom 102'</b> <b>31 m</b>
Extended Boom	<b>112'</b> <b>33,9 m</b>
Fixed or Retracted Jib	<b>137'</b> <b>42 m</b>
Extended Jib	<b>157'</b> <b>48 m</b>

WEIGHTS	30102C
Total Crane - Standard	<b>20,462 lb</b> <b>9 282 kg</b>
Total Crane - Out-and-Down Outriggers	<b>24,612 lb</b> <b>11 164 kg</b>
22' ( <b>6,71 m</b> ) Flat Bed	<b>2,000 lb</b> <b>907 kg</b>
26' ( <b>7,93 m</b> ) Fixed Length Jib	<b>832 lb</b> <b>377 kg</b>
26' - 46' ( <b>7,93 m - 14,02 m</b> ) Telescopic Jib	<b>1,226 lb</b> <b>556 kg</b>

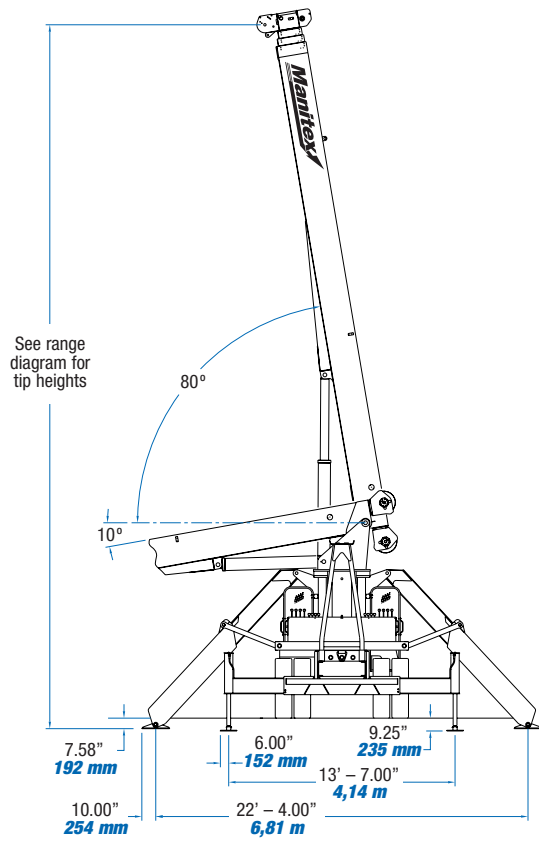

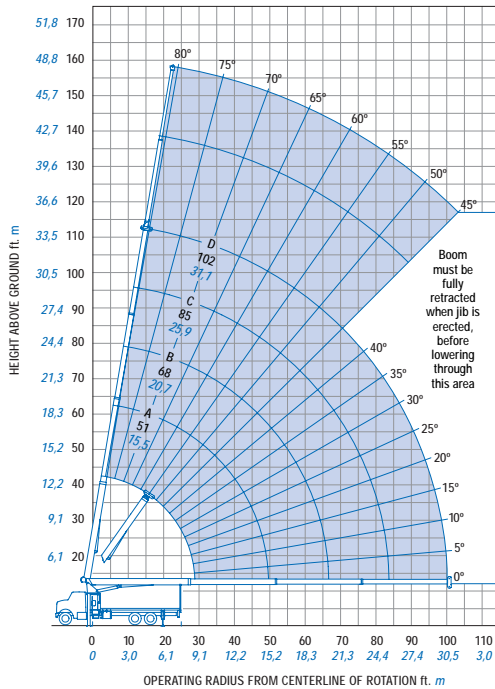

**OUTRIGGERS AND STABILIZERS EXTENDED: MODEL 30102C**

**MAIN BOOM LOAD RATINGS**

**JIB LOAD RATINGS**

Operating Radius	MAIN BOOM LOAD RATINGS										JIB LOAD RATINGS													
	Boom Length		A		B		C		D		Fixed Jib		Telescopic Jib											
	30.5 Feet 9,29 Meters	51 Feet 15,54 Meters	68 Feet 20,72 Meters	85 Feet 25,90 Meters	102 Feet 31,08 Meters	26 Feet 7,92 Meters	26 Feet 7,92 Meters	46 Feet 14,02 Meters	lb.	kg.	lb.	kg.	lb.	kg.	lb.	kg.								
5 1,52	80°	60,000	27 272																					
8 2,43	75°	39,690	18 040																					
10 4,04	71°	33,510	15 231	79	22,500	10 227																		
12 3,65	67°	29,120	13 236	77	22,500	10 227																		
15 4,57	60°	24,440	11 109	73	21,710	9 868	79	20,590	9 359															
20 6,09	48°	19,280	8 763	67	16,910	7 686	74	15,830	7 195	78	14,420	6 554	81	10,500	4 772									
25 7,62	33°	15,480	7 036	61	13,850	6 295	70	12,840	5 836	75	12,180	5 536	78	9,650	4 386	81	5,300	2 409	81	5,100	2 318			
30 9,14				54	11,700	5 318	65	10,770	4 895	72	10,140	4 609	76	8,670	3 940	79	5,300	2 409	79	5,100	2 318	81	3,050	1 386
35 10,66				47	9,770	4 440	60	9,240	4 200	68	8,640	3 927	73	7,670	3 486	77	4,990	2 268	77	4,730	2 150	79	3,050	1 386
40 12,19				38	7,510	3 413	55	7,720	3 509	64	7,490	3 404	70	6,490	2 950	75	4,580	2 081	75	4,310	1 959	77	3,050	1 386
45 13,71				27	5,910	2 686	50	6,110	2 777	60	6,220	2 827	66	5,590	2 540	72	4,190	1 904	72	3,910	1 777	76	3,050	1 386
50 15,24							43	4,920	2 236	56	5,030	2 286	63	4,860	2 209	70	3,830	1 750	70	3,550	1 613	74	2,910	1 322
55 16,76							36	3,990	1 813	51	4,100	1 863	60	4,160	1 890	68	3,480	1 581	68	3,110	1 413	72	2,740	1 245
60 18,28							28	3,250	1 477	47	3,360	1 527	56	3,420	1 554	65	3,020	1 372	65	2,670	1 213	70	2,590	1 177
65 19,81							15	2,630	1 195	41	2,760	1 254	53	2,820	1 281	63	2,630	1 195	63	3,200	1 036	68	2,410	1 095
70 21,33										36	2,250	1 022	49	2,320	1 054	60	2,310	1 050	60	1,950	886	66	2,130	968
75 22,86										29	1,820	827	45	1,890	859	57	2,010	913	57	1,670	759	63	1,880	854
80 24,38										19	1,450	659	40	1,530	695	54	1,640	745	54	1,340	609	61	1,610	731
85 25,90													36	1,210	550	51	1,320	600	51	1,030	468	59	1,400	636
90 27,43													29	930	422	48	1,050	477	48	750	340	56	1,200	545
95 28,96													22	690	313	45	800	363	45	500	227	54	970	440
100 30,48																42	580	263				51	750	340
105 32,00																						48	550	250
		490	222	290	131	220	100	180	81	150	68	Deductions: Stowed Fixed Jib												
		730	331	440	200	330	150	260	118	220	100	Deductions: Stowed Telescopic Jib												

Meets ANSI B30.5 Requirements - Do not operate crane or accessories within 10' (3.05m) of live power lines.  
 NOTICE: This chart is for reference only and must not be used for lifting purposes. Consult factory for other boom options.

## AREA OF OPERATION

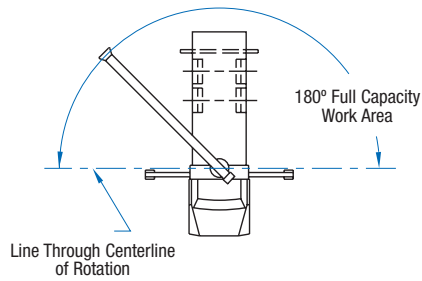

## DEDUCTIONS

Auxiliary Block	<b>50 lb</b> <b>22.72 kg</b>
Auxiliary Block	<b>50 lb</b> <b>22.72 kg</b>
Load Block	<b>See block manufacturer nameplate</b>
Overhaul Ball	<b>See overhaul ball manufacturer nameplate</b>
Hose Reel	<b>140 lb</b> <b>63.64 kg</b>
Swing Around Jib* (Stowed)	<b>See load rating chart</b>

## WEIGHTS

1 Part Line	2 Part Line	3 Part Line	4 Part Line	5 Part Line	6 Part Line	7 Part Line	<b>WARNING</b>
							<p>Anti-two-block system must be in good operating condition before operating crane. Refer to the owner's manual. Keep at least three wraps of load line on the drum at all times.</p> <p><b>.5625" rot resistant (5.0:1 SF) - 37000 lb. min. breaking strength</b></p> <p><b>.5625" 6 x 25 IWRC (3.5:1 SF) - 29750 lb. min. breaking strength</b></p>
<b>8,500 lb</b> <b>3 864 kg</b>	<b>17,000 lb</b> <b>7 727 kg</b>	<b>25,500 lb</b> <b>11 591 kg</b>	<b>34,000 lb</b> <b>15 455 kg</b>	<b>42,500 lb</b> <b>19 318 kg</b>	<b>51,000 lb</b> <b>23 182 kg</b>	<b>60,000 lb</b> <b>27 273 kg</b>	
<b>7,400 lb</b> <b>3 364 kg</b>	<b>14,800 lb</b> <b>6 727 kg</b>	<b>22,200 lb</b> <b>10 091 kg</b>	<b>29,600 lb</b> <b>13 455 kg</b>	<b>37,000 lb</b> <b>16 818 kg</b>	<b>44,400 lb</b> <b>20 182 kg</b>	<b>51,800 lb</b> <b>23 545 kg</b>	

## BOOM AND JIB COMBINATIONS

30102C

102'

4 - Section Boom

26' - 46' 2 - Section Jib

