

CHASSIS DATA	35100C/35124C
Wheelbase (WB)	<b>271"</b> <b>6 883 mm</b>
Cab to Tandem (CT)	<b>202"</b> <b>4 877 mm</b>
After Frame (AF)	<b>114"</b> <b>2 896 mm</b>
Frame Section Modulus at 180° Area of Operation	<b>30.0 in<sup>3</sup></b> <b>125,000 psi</b> <b>861 875 kPa</b>
Frame Section Modulus at 360° of Operation	<b>30.0 in<sup>3</sup></b> <b>125,000 psi</b> <b>861 875 kPa</b>
Front Axle Gross Weight Rating	<b>20,000 lb</b> <b>8 165 kg</b>
Rear Axle Gross Weight Rating	<b>40,000 lb</b> <b>18 144 kg</b>
Minimum Truck Axle Weight - Front**	<b>8,450 lb</b> <b>3 674 kg</b>
Minimum Truck Axle Weight - Back**	<b>8,300 lb</b> <b>3 765 kg</b>
Nominal Frame Width	<b>34"</b> <b>864 mm</b>

\*Frame section modulus at 360P area of operation requires front bumper stabilizer.  
 \*\*Minimum chassis weight is required to meet 85% stability requirements.  
 Chassis data is general - not for engineering. Some dimensions depend on truck selection.

MAXIMUM TIP HEIGHT	35100C	35124C
Configuration	<b>Boom 100'</b> <b>30,5 m</b>	<b>Boom 124'</b> <b>37,8 m</b>
Extended Boom	<b>111' 4"</b> <b>33,9 m</b>	<b>134' 8"</b> <b>41,1 m</b>
Fixed or Retracted Jib	<b>142' 1"</b> <b>43,3 m</b>	<b>165' 11"</b> <b>50,6 m</b>
Extended Jib	<b>166' 8"</b> <b>50,8 m</b>	—

WEIGHTS	35100C	35124C
Total Crane - Out-and-Down Outriggers	<b>29,706 lb</b> <b>13 502 kg</b>	<b>31,126 lb</b> <b>14 148 kg</b>
22' (6,71 m) Flat Bed	<b>2,000 lb</b> <b>907 kg</b>	<b>2,000 lb</b> <b>907 kg</b>
30' 6" (9,30 m) Fixed Length Jib	<b>1,126 lb</b> <b>511 kg</b>	—
31' (9,45 m) Fixed Length Jib	—	<b>850 lb</b> <b>386 kg</b>
30' 6" - 55' (9,30 m - 16,80 m) Telescopic Jib	<b>1,754 lb</b> <b>796 kg</b>	—

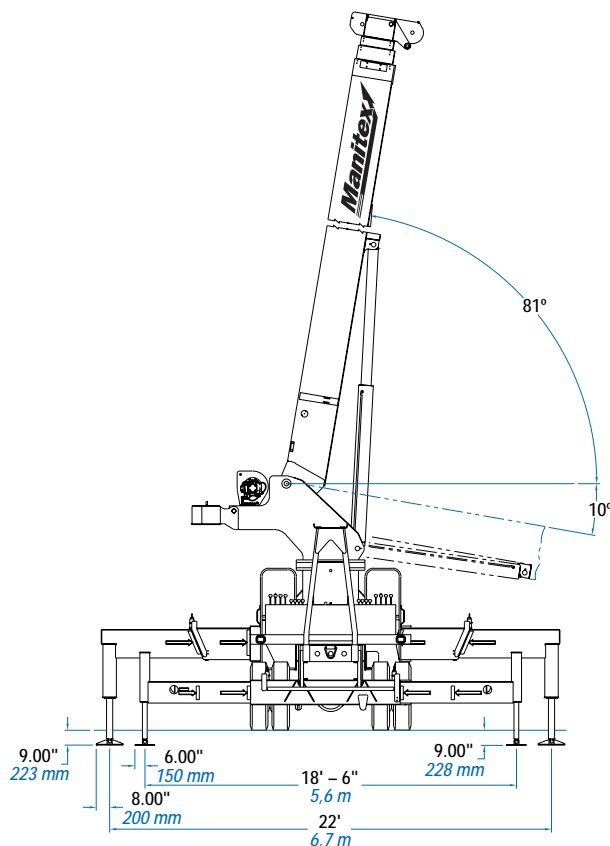

USE THIS CHART ONLY WHEN  
OUTRIGGERS AND STABILIZERS ARE  
FULLY EXTENDED.

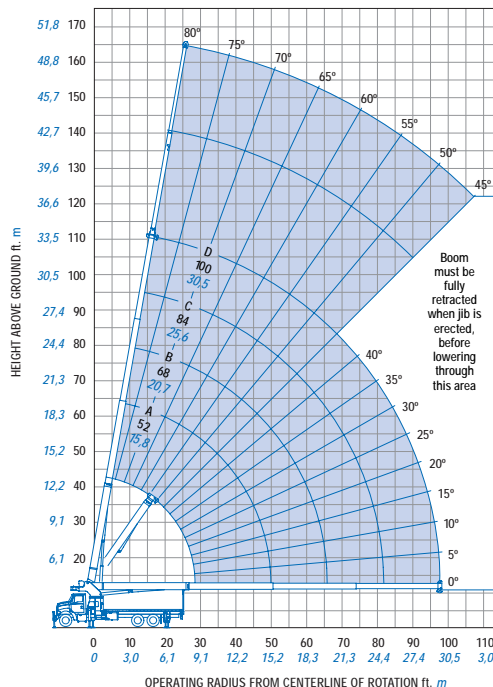
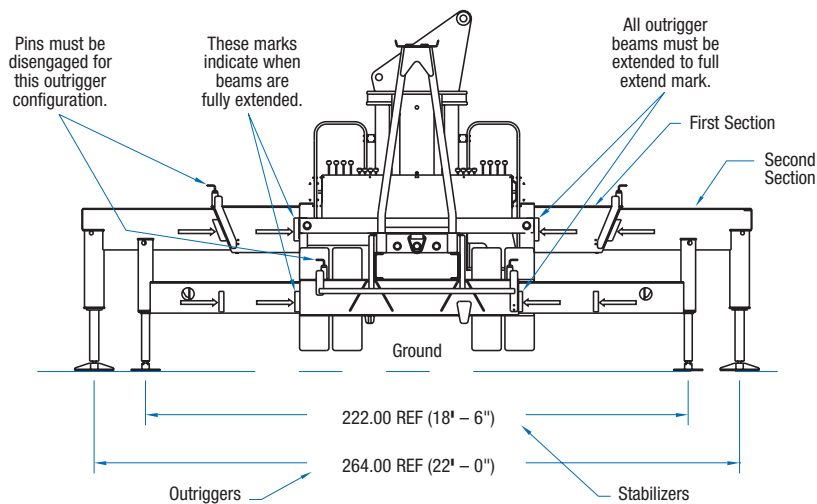

### FULLY EXTENDED OUTRIGGER SPREAD: MODEL 35100C

#### MAIN BOOM LOAD RATINGS

#### JIB LOAD RATINGS

Operating Radius	Boom Length		A		B		C		D		Fixed Jib		Telescopic Jib					
	30.5 Feet 9,29 Meters		52 Feet 15,84 Meters		68 Feet 20,72 Meters		84 Feet 38,18 Meters		100 Feet 30,48 Meters		30.5 Feet 9,29 Meters		30.5 Feet 9,29 Meters		55 Feet 16,76 Meters			
	Feet	Meters	lb.	kg.	lb.	kg.	lb.	kg.	lb.	kg.	lb.	kg.	lb.	kg.	lb.	kg.		
6	1,82	80°	70,000	31 818														
8	2,43	76°	53,500	24 318														
10	4,04	72°	45,670	20 759														
12	3,65	68°	39,830	18 104	78	31,500	14 318											
15	4,57	61°	33,660	15 300	75	30,330	13 786	79	28,500	12 954								
20	6,09	49°	24,380	11 036	69	23,790	10 813	75	22,580	10 263	79	21,780	9 900	80	14,000	6 363		
25	7,62	33°	18,310	8 322	62	18,810	8 550	70	18,470	8 395	75	17,690	8 040	78	13,500	6 136		
30	9,14				56	14,700	6 681	65	14,850	6 750	71	14,760	6 709	75	13,000	5 909		
35	10,66				48	11,350	5 159	60	11,530	5 240	67	11,630	5 286	72	11,700	5 318		
40	12,19				40	8,910	4 050	55	9,070	4 122	63	9,170	4 168	69	9,240	4 200		
45	13,71				29	7,120	3 236	50	7,290	3 313	59	7,380	3 354	66	7,440	3 381		
50	15,24							43	5,930	2 695	55	6,020	2 736	62	6,080	2 763		
55	16,76							36	4,860	2 209	51	4,950	2 250	59	5,000	2 272		
60	18,28							27	3,990	1 813	46	4,080	1 854	55	4,140	1 881		
65	19,81							12	3,280	1 490	40	3,370	1 531	51	3,430	1 559		
70	21,33										34	2,770	1 259	47	2,830	1 286		
75	22,86										27	2,270	1 031	43	2,320	1 054		
80	24,38										15	1,830	831	38	1,880	854		
85	25,90											33	1,500	681	52	1,680	763	
90	27,43											26	1,170	531	49	1,350	613	
95	28,96											17	870	395	45	1,050	477	
100	30,48														42	790	359	
105	32,00														38	550	250	
110	33,52															47	560	254
			600	273	350	159	270	123	220	100	180	82	Deductions: Stowed Fixed Jib					
			900	409	530	241	400	182	330	150	290	132	Deductions: Stowed Telescopic Jib					

Meets ANSI B30.5 Requirements - Do not operate crane or accessories within 10' (3,05m) of live power lines.

NOTICE: This chart is for reference only and must not be used for lifting purposes. Consult factory for other boom options.

## AREA OF OPERATION

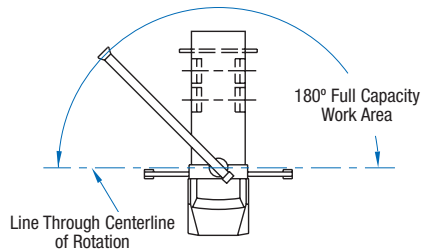

## DEDUCTIONS

Auxiliary Block	<b>50 lb</b> <b>22.72 kg</b>
Load Block	<b>See block manufacturer nameplate</b>
Overhaul Ball	<b>See overhaul ball manufacturer nameplate</b>
Hose Reel	<b>260 lb</b> <b>118.18 kg</b>
Swing Around Jib* (Stowed)	<b>See load rating chart</b>

## WEIGHTS

1 Part Line	2 Part Line	3 Part Line	4 Part Line	5 Part Line	6 Part Line	7 Part Line	8 Part Line	<b>WARNING</b>
								<p>Anti-two-block system must be in good operating condition before operating crane. Refer to the owner's manual. Keep at least three wraps of load line on the drum at all times.</p> <p>.625" rot resistant (5.0:1 SF) - 45400 lb. min. breaking strength</p> <p>.625" 6 x 25 IWRC (3.5:1 SF) - 33250 lb. min. breaking strength</p>
<b>9,080 lb</b> <b>4 127 kg</b>	<b>18,160 lb</b> <b>8 254 kg</b>	<b>27,240 lb</b> <b>1 238 kg</b>	<b>36,320 lb</b> <b>16 509 kg</b>	<b>45,400 lb</b> <b>20 636 kg</b>	<b>54,480 lb</b> <b>24 763 kg</b>	<b>63,560 lb</b> <b>28 890 kg</b>	<b>70,000 lb</b> <b>31 818 kg</b>	
<b>9,500 lb</b> <b>4 318 kg</b>	<b>19,000 lb</b> <b>8 636 kg</b>	<b>28,500 lb</b> <b>12 954 kg</b>	<b>38,000 lb</b> <b>17 272 kg</b>	<b>47,500 lb</b> <b>21 590 kg</b>	<b>57,000 lb</b> <b>25 909 kg</b>	<b>66,500 lb</b> <b>30 227 kg</b>	<b>70,000 lb</b> <b>31 818 kg</b>	

## BOOM AND JIB COMBINATIONS

3577C	77' Powered	3 Section Boom	
35100C	100'	4 Section Boom	31' - 55' 2- Section Jib
35124C	124'	5 Section Boom	31' 1- Section Jib