

# LORAIN<sup>®</sup> LRT 400 SERIES

rough terrain crane  
specifications

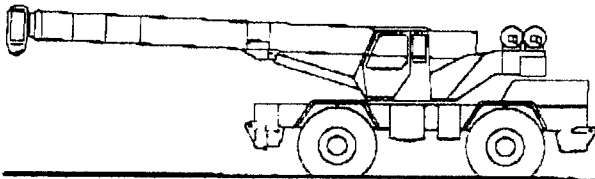

---

## STANDARD BOOM EQUIPMENT

### BOOM

33–105 ft. (10.06–32.00 m), four section full power boom. Telescoping is fully synchronized with single lever control. High-strength, four plate construction with side plate holes providing reduced weight. Anti-friction slide pads. Single boom hoist cylinder.

### BOOM HEAD

Welded to fourth section of boom. Four or five metallic sheaves and two idler sheaves mounted on heavy duty, anti-friction bearings. Quick reeving boom head eliminates need to remove wedge and socket from rope. Provision made for side-stow jib mounting.

---

## OPTIONAL BOOM EQUIPMENT

### JIBS

33 ft. (10.06 m) side stow swing-on one-piece lattice type jib. Single metallic sheave mounted on anti-friction bearing. Jib is offsettable at 0°, 15°, or 30°.

33–58 ft. (10.06–17.68 m) side stow swing-on lattice type jib. Single sheave mounted on anti-friction bearing. Jib is extendible to 58 ft. (17.68 m) by means of a 25 ft. (7.62 m) manual pull-out tip section, roller supported for ease of extension. Jib is offsettable at 0°, 15°, or 30°. Maximum tip height is 167 ft. (50.9 m).

### AUXILIARY BOOM HEAD

Removable auxiliary boom head has single metallic sheave mounted on anti-friction bearing. Removable pin-type rope guard for quick reeving. Installs on main boom peak only.

### HOOK BLOCK

Three, four or five metallic sheaves and hook latch. Quick reeving design.

### HOOK & BALL

6.25 ton (5.7 mt) top swivel ball with hook and hook latch.

# GENERAL DIMENSIONS

## NOTE:

Dimensions given assume the boom is fully retracted in travel position and 21:00 x 25 tires.

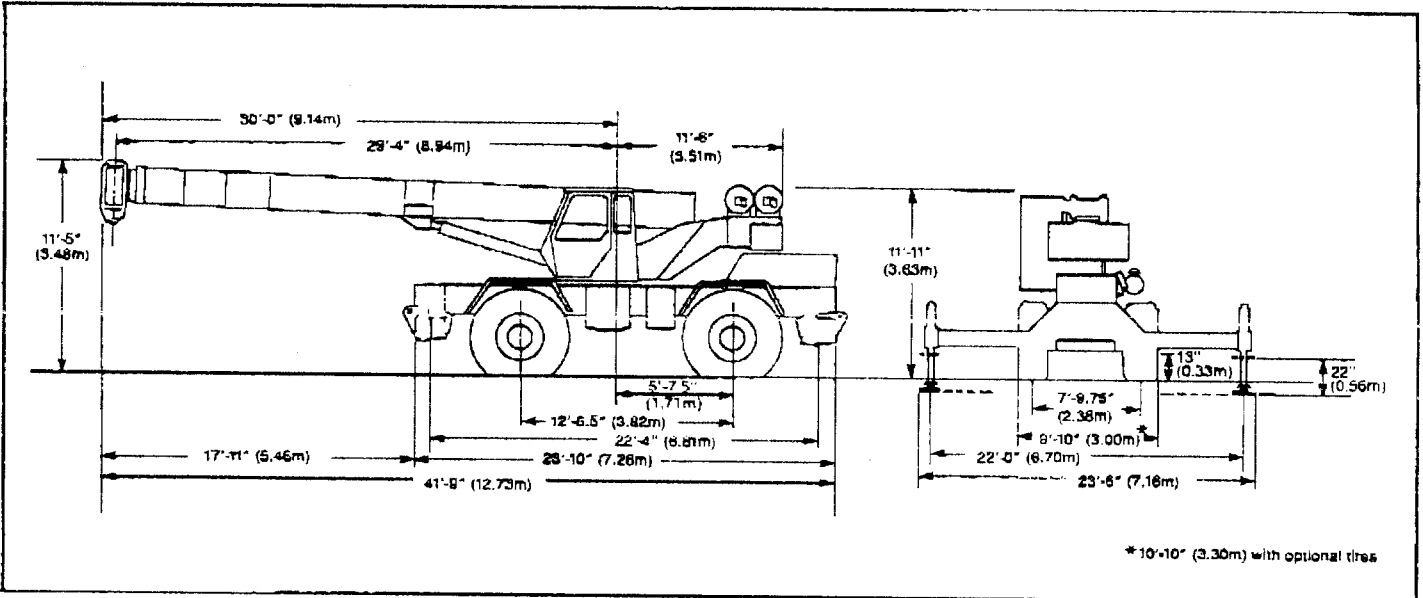

WEIGHTS & AXLE LOADS	GROSS WEIGHT LBS.	UPPER IN TRAVEL POSITION		GROSS WEIGHT Kg	UPPER IN TRAVEL POSITION	
		FRONT	REAR		FRONT	REAR
Basic Crane with 105' (32.00 m) Boom 12,000 lb (5443 kg) Counterweight, 21:00 x 25, 28 P.R. Tires	71,900	37,900	34,000	32 614	17 191	15 423
<b>Add Options:</b>						
33' (10.06 m) Swing-on Jib (Stowed)	+ 1,640	+ 2,040	- 400	+ 744	+ 925	- 181
33'-58' (10.06-17.68 m) Swing-on Jib (Stowed)	+ 2,540	+ 4,080	- 1,540	+ 1152	+ 1851	- 699
45 ton (40.8 mt) Hook Block	+ 750	+ 1,175	- 425	+ 340	+ 533	- 193
Auxiliary Winch with Wire Rope	- 100	+ 138	- 238	- 45	+ 63	- 108
<b>Substitute:</b>						
26:50 x 25, 26 P.R. Tires	+ 400	+ 200	+ 200	+ 182	+ 91	+ 91

NOTE: Weights are for Lorain supplied equipment and subject to 2% variation due to manufacturing tolerances.

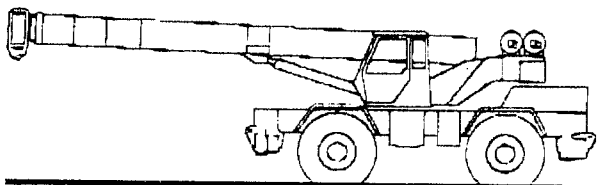

## STANDARD UPPERSTRUCTURE EQUIPMENT

### UPPERSTRUCTURE FRAME

All welded one-piece structure fabricated with high tensile strength alloy steel. Counterweight is bolted to frame.

### TURNTABLE CONNECTION

Swing bearing is single row, ball-type, with internal teeth. The swing gear is bolted to revolving upperstructure and to carrier frame.

### SWING

A hydraulic motor drives a double planetary reduction gear for precise and smooth swing function. Swing speed (no load) is 3.0 rpm.

### SWING BRAKE

Heavy duty, multiple disc swing brake is mechanically actuated from operator's cab by foot pedal. Brake may be operated to hold upperstructure at any desired degree of rotation. Brake is released by hand.

### RATED LOAD INDICATOR

Rated Load Indicator with visual and audio warning system, electronic boom angle, boom length and relative load moment indicator with automatic function disconnects. On-screen display includes: boom radius, boom length, allowable load, actual load and percentage of allowable load registered numerically and by bar graph. Anti-two block system with audio/visual warning and automatic function disconnects.

### OPERATOR'S CAB

Environmental cab with all steel construction, optimum visibility, safety glass throughout and rubber floor matting is mounted on vibration absorbing pads. The cab has a sliding door on the left side, sliding windows on the right side, hinged tinted Lexan® skylight and removable front windshield. Acoustical foam padding insulates against sound and weather. The deluxe six-way adjustable operator's seat includes head and arm rests.

### CONTROLS

All control levers and pedals are positioned for efficient operation. Hand-operated control levers include swing, boom telescope, boom hoist, single lever two-speed main winch, and hand throttle. Foot control pedals include boom raise, boom lower, accelerator and swing brake.

### INSTRUMENTATION AND ACCESSORIES

In-cab gauges include air pressure, bubble level, engine oil pressure, fuel, engine temperature, voltmeter, transmission temperature, and transmission oil pressure. Switches include ignition, engine stop, steering mode, and outrigger controls. Indicators include low air, high water temperature/low oil pressure audio/visual warning, high transmission temperature and Rated Load Indicator. Accessories include fire extinguisher; light package including headlights, tail lights, brake lights, directional signals, four-way hazard flashers, and back-up lights with audio pulsating back-up alarm; windshield washer/wiper; R. H. and L. H. rear view mirror; dash light; and seat belt.

### HYDRAULIC CONTROL VALVES

Valves are mounted on the upperstructure and are easily accessible. Valves include one four-spool main valve for boom hoist, telescope, main winch, and main winch boost; and one single-spool valve for swing. Quick disconnects are provided for quick connection of pressure check gauges.

### OPTIONAL EQUIPMENT

Auxiliary Winch • Winch Cable Rollers • Drum Rotation Indicators • 360° House Lock • Heater/Defroster • Air Conditioner • Tinted Safety Glass • Vandal and Scratch Resistant Glass • Torsion Bar Suspension for Bucket Seat • Roof Window Electric Wiper • Tachometer • Work Lights

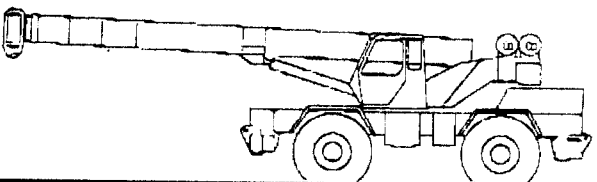

## STANDARD CARRIER EQUIPMENT

### CARRIER CHASSIS

Chassis is Lorain designed and built with four-wheel drive and four-wheel steer (4x4x4). Has box-type construction with reinforcing cross members, a precision machined turntable mounting plate and integrally welded outrigger boxes. Decking has anti-skid surfaces, including tool storage compartment and access ladders left and right side and front and rear corners.

### AXLES AND SUSPENSION

Rear axle is a planetary drive/steer type with automatic oscillation lockouts that engage when the superstructure is swung 10° in either direction. Front axle is a planetary drive/steer type, rigid mounted to the frame for increased stability.

### STEERING

Hydraulic four-wheel power steering for two-wheel, four-wheel, or crab steer is easily controlled by steering wheel.

Turning radius to center of outside tire.

	(standard tires)	(optional tires)
Two-wheel:	40'0" (12.2 m)	40'4" (12.3 m)
Four-wheel:	23'0" (7.0 m)	23'4" (7.1 m)

### TRANSMISSION

Full power-shift transmission with integral torque converter has neutral safety start, 6 speeds forward, and 3 speeds reverse. Automatic pulsating backup alarm.

# STANDARD CARRIER EQUIPMENT (continued)

## OUTRIGGERS

POWRSPAN® out and down fully independent hydraulic outriggers extend 22 ft. centerline to centerline. Easily removable steel floats, each with an area of 254 in<sup>2</sup> (1639 cm<sup>2</sup>), stow on the carrier frame. Complete controls and sight leveling bubble are located in the operator's cab.

## WHEELS & TIRES

Disc type wheels with full tapered bead seat rim. 150.50 in. (3.82 m) wheelbase.

## TIRES

21:00x25, 28 P.R. (standard)  
26.50x25, 26 P.R. (optional)

## SERVICE BRAKES

Cam-operated air brakes on all four wheels; 20 1/4" x 4" (51.43 x 101.6 cm) braking area.

## PARKING BRAKE

Front and rear axles equipped with spring-set, air-released emergency/parking chambers.

## OPTIONAL EQUIPMENT

Cold Weather Starting Aid • Immersion Heater • Rear Axle Centering Light • Pintle Hook • Fuel Water Separator • Clearance Lights

# HYDRAULIC SYSTEM

## HYDRAULIC PUMPS

Three gear type pumps, one single and two in tandem, driven off the transmission. Combined system capability is 119 gpm (450 lpm). Includes pump disconnect.

### Main and Auxiliary Winch Pump

59.5 gpm (225.2 lpm) @ 3,500 psi (246.1 kg/cm<sup>2</sup>)

### Boom Hoist, Telescope Pump

38.5 gpm (145.7 lpm) @ 3,500 psi (246.1 kg/cm<sup>2</sup>)

### Power Steering, Outrigger and Swing Pump

21 gpm (79.5 lpm) @ 2,500 psi (175 kg/cm<sup>2</sup>)

## FILTRATION

Full flow oil filtration system with bypass protection includes a removable 100 mesh (140 micron) suction screen-type filter and 5 micron replaceable return line filter.

## HYDRAULIC RESERVOIR

All steel, welded construction with internal baffles and diffuser. Provides easy access to filters and is equipped with an external sight level gauge. The hydraulic tank is pressurized to aid in keeping out contaminants and in reducing potential pump cavitation. Capacity is 112 gal. (424 liters). Swing-away hydraulic oil cooler is standard.

# MAIN WINCH SPECIFICATIONS

Lorain built hydraulic winch with planetary reduction gearing provides 2-speed operation with equal speeds for power up and down. Winch is equipped with an integral automatic brake.

PERFORMANCE	LO-RANGE	HI-RANGE
Max. line speed (no load)		
First layer	177 fpm (54 m/min)	293 fpm (89 m/min)
Fifth layer	257 fpm (78 m/min)	426 fpm (130 m/min)
Max. line pull—First layer	15,000 lbs (6804 kg)	
Permissible line pull	10,000 lbs (4536 kg)	
DRUM DIMENSIONS	DRUM CAPACITY	
10.5 in (267 mm) drum diameter	Max. Storage: 899 ft (274 m)	
20.9 in (531 mm) length	7th layer not working layer	
19.8 in (503 mm) flange dia.	Max Useable: 738 ft (225 m)*	
Cable: 5/8 in x 500 ft (15.9 mm x 137.2 m)		
Cable type: 6 x 19 IWRC-XIPS regular lay preformed	*Based on minimum flange height above top layer to comply with ANSI B30.5	

## OPTIONAL AUXILIARY WINCH

Lorain hydraulic winch, power up and down, equal speed, planetary reduction with integral automatic brake.

### PERFORMANCE

Max. line speed (no load)  
  Fifth layer 338 fpm (103 m/min)  
Max. line pull  
  First layer 10,100 lbs (4582 kg)

### DRUM DIMENSIONS

10.5 in (267 mm) drum diameter  
16.1 in (409 mm) length  
17.8 in (452 mm) flange diameter  
Cable: 1/2 in x 500 ft (12.7 mm x 152.4 m)  
Cable type: 6 x 19 IWRC-XIPS regular lay preformed

### DRUM CAPACITY

Max. storage: 815 ft (248 m)

# ENGINE SPECIFICATIONS

Make and Model	Cummins 6BT5.9
Type	6 cylinder
Bore and Stroke	4.02 x 4.72 in (102 x 120 mm)
Displacement	359 cu in (5.9 l)
Max. Gross Horsepower	177 hp (132 kw) @ 2500 rpm
Max. Gross Torque	455 lb-ft/1500 rpm
Aspiration	turbocharged, aftercooled
Air Filter	dry type
Electrical System	12 volt
Alternator	102 amp
Battery	(2) 12V-1250 C.C.A.
Fuel Capacity	50 gal (189 l)

## OPTIONAL HOIST LINE

**MAIN WINCH**—5/8" (14.29 mm) rotation resistant, compacted strand, 18 x 19 or 19 x 19. Minimum break strength 22.7 tons (20.4 mt).

**OPTIONAL AUXILIARY WINCH**—5/16" (15.88 mm) rotation resistant, compacted strand, 18 x 19 or 19 x 19. Minimum break strength 16.5 tons (16.6 mt).

# LORAIN® LRT 400 SERIES

rough terrain hydraulic crane  
45 ton capacity

range diagram &  
capacity charts

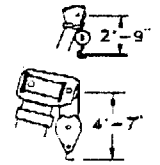
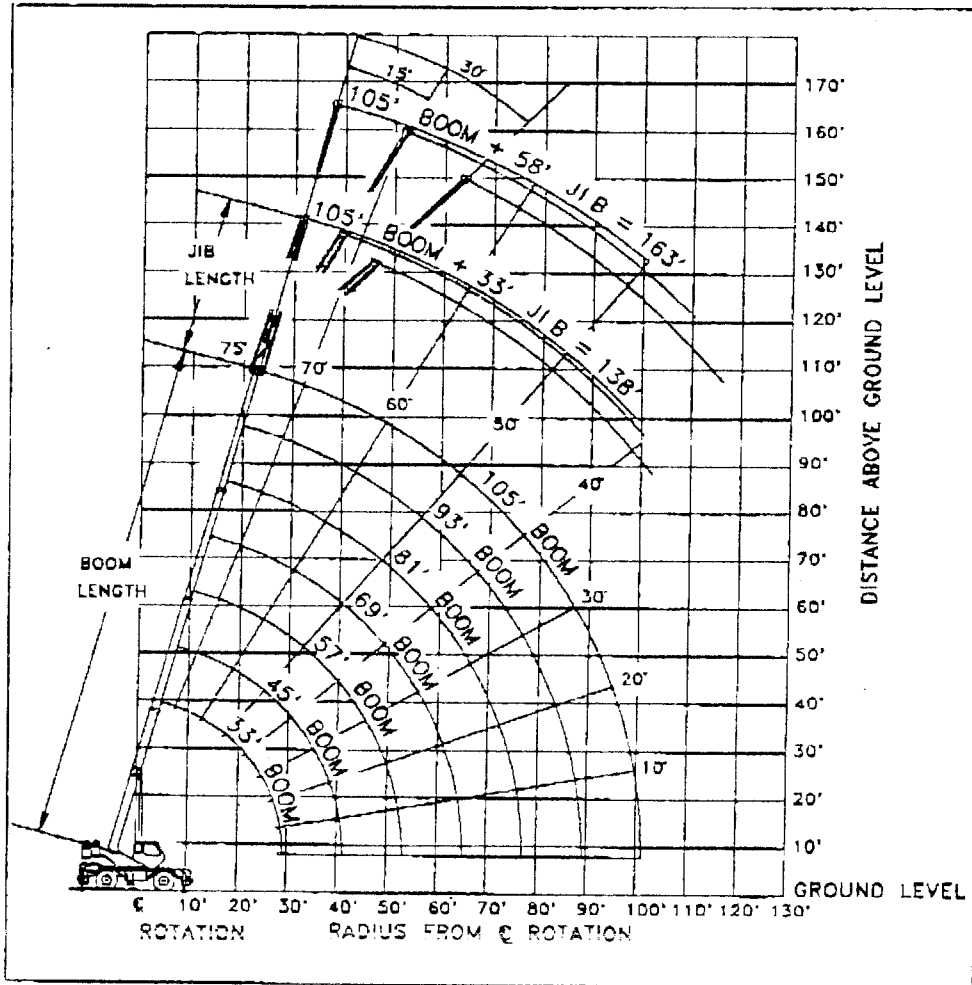

DIMENSIONS ARE FOR LARGEST KOEHRING FURNISHED HOOK BLOCK AND HEADACHE BALL WITH ANTI-TWO BLOCK ACTIVATED.

**Range Diagram (33'-105' boom)**

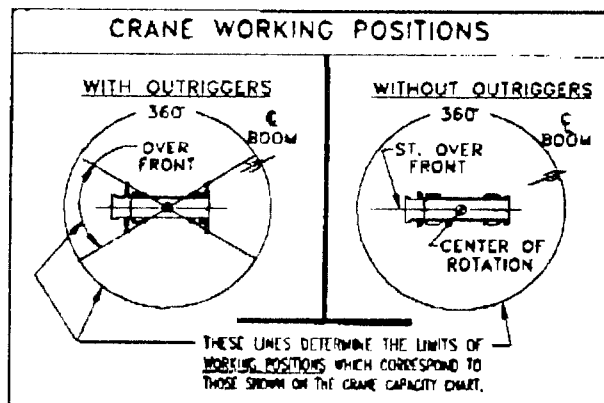

# Capacity Charts—Pounds (33'-105' boom)

# LRT 400 SERIES

CAPACITY: 45 TON

COUNTERWEIGHT:

W/AUX. WINCH 10,900 lb.

W/O AUX. WINCH 12,000 lb.

BOOM LENGTH 33-105 ft.

OUTRIGGER SPREAD 22 ft.

STABILITY PCT.

ON OUTRIGGERS 85%  
ON TIRES 75%

**IMPORTANT:** This specification sheet is not to be used as load rating chart in the machine as data may be subject to change

## ON OUTRIGGERS

RAD. I. U. S.	BOOM LENGTH 33'		BOOM LENGTH 45'		BOOM LENGTH 57'		BOOM LENGTH 69'		BOOM LENGTH 81'		BOOM LENGTH 93'		BOOM LENGTH 105'		RAD. I. U. S.	
	FRONT 360°		FRONT 360°		FRONT 360°		FRONT 360°		FRONT 360°		FRONT 360°		FRONT 360°			
	W	D	W	D	W	D	W	D	W	D	W	D	W	D		
10	67	90,000*	90,000*	74	75,000*	75,000*									10	
12	63	78,100*	78,100*	71	73,000*	72,900*	74	59,600*	59,600*						12	
15	57	64,200*	63,200*	67	61,700*	61,700*	72	55,000*	55,000*	73	43,900*	43,900*			15	
20	46	45,800*	45,300*	60	46,100*	45,800*	66	46,300*	45,700*	71	36,100*	36,100*	75	33,400*	33,400*	20
25	31	34,700*	34,400*	52	35,100*	34,800*	60	35,300*	35,000*	67	30,300*	30,300*	71	28,300*	28,300*	25
30				43	27,800*	27,800*	54	28,000*	27,800*	62	26,000*	26,000*	67	24,200*	24,200*	30
35				32	22,500*	22,400*	47	22,800*	22,800*	57	22,700*	22,700*	63	21,000*	21,000*	35
40				15	17,600*	17,500*	20	18,900*	18,700*	32	19,000*	18,700*	59	18,600*	18,600*	40
45							32	15,800*	14,700*	46	15,800*	15,000*	59	15,800*	15,000*	45
50							20	12,700*	11,700*	39	12,800*	12,100*	50	12,900*	12,200*	50
55										33	10,500*	9,900*	45	10,800*	10,100*	55
60										24	8,600*	8,100*	39	8,800*	8,300*	60
65													33	7,300*	6,900*	65
70													26	6,100*	5,700*	70
75													15	5,000*	4,600*	75
80																80
85																85
90																90
95																95
100																100

## SIDE STOW JIB ON OUTRIGGERS

RAD. I. U. S.	33' OFFSET JIB						58' OFFSET JIB						RAD. I. U. S.
	MAX BOOM & 0' OFFSET 138.6'		MAX BOOM & 15' OFFSET 137.8'		MAX BOOM & 30' OFFSET 134.9'		MAX BOOM & 0' OFFSET 163.6'		MAX BOOM & 15' OFFSET 161.9'		MAX BOOM & 30' OFFSET 156.5'		
	W	D	W	D	W	D	W	D	W	D	W	D	
75	38	9,000*	46	7,200*	52	8,000*	50	5,000*	64	4,000*	75	3,300*	75
73	43	7,700*	50	6,800*	57	5,500*	55	4,700*	69	3,800*	79	3,200*	73
70	50	6,300*	58	5,700*	63	4,900*	63	4,300*	76	3,500*	86	2,900*	70
67	57	5,400*	63	4,900*	69	4,400*	71	3,900*	83	3,200*	92	2,700*	67
64	63	4,500*	69	4,200*	75	3,800*	78	3,300*	80	2,800*	98	2,500*	64
61	70	3,900*	76	3,500*	81	3,300*	86	2,800*	97	2,400*	104	2,200*	61
58	76	3,300*	81	3,000*	86	2,800*	93	2,400*	103	2,100*	110	1,900*	58
54	83	2,700*	88	2,500*	93	2,300*	102	1,900*	111	1,600*	117	1,500*	54
50	90	2,100*	95	2,000*	99	1,900*	110	1,500*	118	1,200*	123	1,200*	50
46	97	1,700*	101	1,600*	105	1,500*	117	1,100*					46
42	103	1,200*	107	1,200*	110	1,100*							42

## REDUCTION IN MAIN BOOM CAPACITY

- ALL JIBS IN STOWED POSITION \_\_\_\_\_ 0 Lbs.
- 33' - 58' OFFSET JIB  
JIB ERRECTED  
STINGER RETRACTED \_\_\_\_\_ 4,800 Lbs.
- 33' - 58' OFFSET JIB  
JIB ERRECTED  
STINGER EXTENDED \_\_\_\_\_ 6,300 Lbs.
- 33' OFFSET JIB  
JIB ERRECTED  
WITHOUT STINGER \_\_\_\_\_ 3,000 Lbs.
- AUX. BOOM HEAD  
SHEAVE \_\_\_\_\_ 110 Lbs.

NOTES FOR 33' BOOM CAPACITIES:  
1. THE 33' BOOM LENGTH CAPACITIES ARE BASED ON THE BOOM FULLY RETRACTED IF NOT FULLY RETRACTED AND AGAINST STOPS. DO NOT EXCEED RATING FOR 45' BOOM LENGTH.

## HOOK BLOCK WEIGHTS

- HOOK & BALL \_\_\_\_\_ 209 Lbs.
- HOOK BLOCK (3 SHEAVE) \_\_\_\_\_ 650 Lbs.
- HOOK BLOCK (4 SHEAVE) \_\_\_\_\_ 700 Lbs.
- HOOK BLOCK (5 SHEAVE) \_\_\_\_\_ 760 Lbs.

## ON TIRES

RAD. I. U. S.	MAX. BOOM LENGTH	21:00 X 25-28PR				26.5 X 25-26PR				RAD. I. U. S.
		STATIONARY		PICK & CARRY		STATIONARY		PICK & CARRY		
		W	D	W	D	W	D	W	D	
10	33'	36,300	74,400*	56,700*	49,700*	38,500*	65,600*	49,700*	41,600*	10
12	33'	27,300	64,900*	49,200*	42,900*	30,800*	57,000*	42,900*	35,800*	12
15	33'	18,400	49,700*	40,700*	35,300*	21,000*	47,300*	35,300*	29,200*	15
20	45'	15,800	28,500	28,500	26,500*	12,400	28,500*	26,500*	21,600*	20
25	45'	6,700	19,000	19,000	18,000	7,800	19,000	19,000	16,400*	25
30	45'	3,900	12,800	12,800	12,800	4,700	12,800	12,800	12,400*	30
35	45'	2,400	9,500	9,500	9,500	3,000	9,500	9,500	9,500	35
40	57'	1,300	7,200	7,200	7,200	1,800	7,200	7,200	7,200	40
45	57'		5,500	5,500	5,500		5,500	5,500	5,500	45
50	57'		4,200	4,200	4,200		4,200	4,200	4,200	50
55	69'		3,100	3,100	3,100		3,100	3,100	3,100	55
60	69'		2,300	2,300	2,300		2,300	2,300	2,300	60

## RECOMMENDED TIRE PRESSURE

TIRE SIZE	STATIONARY	CREEP	2 1/2 MPH	TRAVEL
21:00 X 25-28 PR	85 PSI	85 PSI	85 PSI	65 PSI
26:50 X 25-26 PR	65 PSI	65 PSI	65 PSI	50 PSI

## NOTES FOR ON TIRES CAPACITIES

- FOR PICK AND CARRY OPERATIONS, BOOM MUST BE CENTERED OVER THE FRONT OF THE CRANE WITH SWING BRAKE LOCKED OR WITH MECHANICAL SWING LOCK ENGAGED, IF SO EQUIPPED. USE MINIMUM BOOM POINT HEIGHT AND KEEP LOAD CLOSE TO GROUND SURFACE.
- THE LOAD SHOULD BE RESTRAINED FROM SWINGING. NO ON TIRE OPERATION WITH JIB ERRECTED.
- WITHOUT OUTRIGGERS, NEVER MANUEVER THE BOOM BEYOND LISTED LOAD RADII FOR APPLICABLE TIRES USED TO ENSURE STABILITY.
- CREEP SPEED IS CRANE MOVEMENT OF LESS THAN 200 FT. (61m) IN 30 MINUTES PERIOD AND NOT EXCEEDING 1.0 MPH (1.6 Km/H).
- REFER TO GENERAL NOTES FOR ADDITIONAL INFORMATION.

## NOTES FOR JIB CAPACITIES

- FOR ALL BOOM LENGTHS LESS THAN THE MAXIMUM WITH A JIB ERRECTED, THE RATED LOADS ARE DETERMINED BY BOOM ANGLE ONLY IN THE APPROPRIATE COLUMN.
- FOR BOOM ANGLE NOT SHOWN, USE THE CAPACITY OF THE NEXT LOWER BOOM ANGLE.
- LISTED RADII ARE FOR FULLY EXTENDED BOOM ONLY.
- DO NOT OPERATE 58 FT. JIB BELOW 50° BOOM ANGLE OR 33 FT. JIB BELOW 42° BOOM ANGLE UNLESS THE BOOM IS RETRACTED TO A LENGTH OF 57 FT. OR LESS.

## MAXIMUM PERMISSIBLE HOIST LINE LOAD

LINE PARTS	1	2	3	4	5	6	7	8	9	10
STD. HOIST	10,000	20,000	30,000	40,000	50,000	60,000	70,000	80,000	90,000	90,000
OPT. HOIST	9,080	18,160	27,240	36,320	45,400	54,480	63,560	70,600	81,720	90,000
AUX. HOIST	7,400	14,800	22,200	29,600	37,000	44,400	51,800	59,200	66,600	74,000

MAIN & OPT. AUX. HOIST LINE  
STD - 3/8" 6X19 OR 6X37 CLASS.  
IWRG, REG LAY PREFORMED WIRE ROPE  
MINIMUM BREAKING STRENGTH - 17.9 TONS

OPT - 5/8" NOTATION RESISTANT  
COMPACTED STRAND, 18X19 OR 18X19  
MINIMUM BREAKING STRENGTH - 22.7 TONS

AUX. HOIST LINE  
STD - 1/2" 6X19 OR 6X37 CLASS.  
IWRG, REG LAY PREFORMED WIRE ROPE  
MINIMUM BREAKING STRENGTH - 13.3 TONS

OPT - 9/16" NOTATION RESISTANT  
COMPACTED STRAND, 18X19 OR 19X19  
MINIMUM BREAKING STRENGTH - 19.3 TONS

# General Notes

## GENERAL

- 1 Review Operator's Manual prior to operating this crane
- 2 Crane load ratings as determined by boom length, radius, and boom angle apply to this crane only as originally manufactured and equipped. **THEY ARE MAXIMUM LOAD RATINGS.**
- 3 This crane and its load ratings are in accordance with Power Crane & Shovel Association Standard No. 4 SAE Crane Load Stability Test Code J-765a SAE Method of Test for Crane Structure J1063 and Safety Code for Cranes, Derricks and Hoists, ANSI B30.5-1989
- 4 Improperly operated or maintained equipment can be dangerous. The operator and other personnel should read and fully understand the Operator's Manual furnished by the manufacturer before operating or maintaining this crane. Rules for safe operation of equipment should be adhered to at all times. If either Manuals or a lift chart are missing, these should be ordered by crane serial number through the distributor.
- 5 Operators and supervisors must fully understand Safety Standards for Mobile Hydraulic Cranes ANSI B30.5 or latest, and be familiar with Federal, State, and local safety regulations.

## SET-UP

- 6 Crane load ratings are based on the crane being leveled and standing on a firm, uniform supporting surface
- 7 Crane load ratings on outriggers are based on all outrigger beams fully extended and the tires raised free of the supporting surface
- 8 Crane load ratings on tires depend on appropriate inflation pressure and tire conditions. Caution must be exercised when increasing air pressures in tires. Consult Operator's Manual for precautions
- 9 Use of jibs, lattice-type boom extension, or fourth section pullout extended is not permitted for pick and carry operations
- 10 Consult appropriate section of the Operator's and Service Manual for more exact description of hoist line reeving
- 11 The use of more parts of line than required by the load may result in having insufficient rope to allow the hook block to reach the ground
- 12 Properly maintained wire rope is essential to safe crane operation. Consult Operator's Manual for proper maintenance and inspection requirements.
- 13 When spin-resistant wire rope is used, the allowable rope loading shall be the breaking strength divided by five (5) unless otherwise specified by the wire rope manufacturer.

## OPERATION

- 14 Crane load ratings must not be exceeded. **DO NOT ATTEMPT TO TIP THE CRANE TO DETERMINE ALLOWABLE LOADS**
- 15 Crane load ratings are for lift crane service. Applications for other than lift crane (clamshell and magnet) are permitted. Due to significant variation in materials and applications, consult factory for optimum capability.

- 16 Weight of hooks, hook blocks, slings and all other load handling devices must be considered part of the load to be handled and must be subtracted from the load ratings to obtain the allowable load to be lifted
- 17 Crane load ratings are based on freely suspended loads. **SIDE LOAD ON BOOM OR JIB IS EXTREMELY DANGEROUS**
- 18 Practical working loads depend on the supporting surface, wind velocity, pendulum action, jerking or sudden stopping of loads, hazardous surroundings, experience of personnel and proper operation, tire inflation, tire condition, traveling with loads, multiple crane lifts, proximity of electrical wires, etc. Appropriate reduction of load ratings must be made for these and any other conditions which may affect practical working loads
- 19 Crane load ratings with an asterick (\*) beside them are based on the crane's structure strength. All other ratings are based on stability and do not exceed the specified percentage of tipping load as determined by SAE Crane Stability Test Code J-765a
- 20 When either radius or boom length, or both, are between listed values, the smaller of the two load ratings shall be used
- 21 Do not operate at longer radii than those listed on the applicable load rating chart as tipping can occur without a load on the hook
- 22 Power telescoping boom sections must be extended equally
- 23 Load ratings are dependent upon the crane being maintained according to manufacturer's specifications.
- 24 The maximum load which may be telescoped is limited by boom angle, hydraulic pressure, boom lubrication, etc. It is safe to attempt to extend and retract within the limits to the capacity chart.
- 25 It is recommended that load handling devices, including hooks, and hook blocks, be kept away from boom head at all times
- 26 The boom angles shown on the capacity chart give an approximation of the operating radius for a specified boom length. The boom angle, before loading, should be greater to account for boom deflection. It may be necessary to retract the boom if maximum boom angle is insufficient to maintain rated radius
- 27 For MCH carrier-mounted cranes only 360° capacities apply only to machine equipped with front outrigger jack with all five (5) outrigger jacks properly set. For 360° lift capacities, use Over Side capacity chart.

## DEFINITIONS

- 28 Operating Radius: The horizontal distance from the axis of rotation before loading to the center of the vertical hoist line or tackle with a load applied.
- 29 Freely Suspended Load: Load hanging free with no direct external force applied except by the hoist rope
- 30 Side Load: Horizontal force applied to the lifted load either on the ground or in the air
- 31 Working Area: Areas measured in a circular arc around the centerline of rotation as shown on the working area diagram