

HIAB 035 Capacity 4 tm



Product brochure

www.hiab.com



HIAB 035 Capacity 4 tm

The HIAB 035 provides total reliability

The HIAB 035 is a crane that succeeds in being an exceptionally compact crane that can turn your light truck into a highly versatile multi-purpose vehicle. The HIAB 035 has also been specially constructed to handle tough jobs like digging and grapple work. The crane features the BOSS intelligence system for safety, and is controlled via levers positioned at the base. The cross control system can be delivered as an option, improving safety and versatility.

Compact

> **Column close to centreline**

On Hiab cranes with a rack-and-pinion slewing housing the centre of gravity is as close to the centreline as possible. This means that the same outreach is offered on both sides of the truck.

> **Rack and pinion slewing**

The rack and pinion slewing mechanism provides very high torque. The technique is simple and reliable and thus keeps maintenance costs down and productivity up.

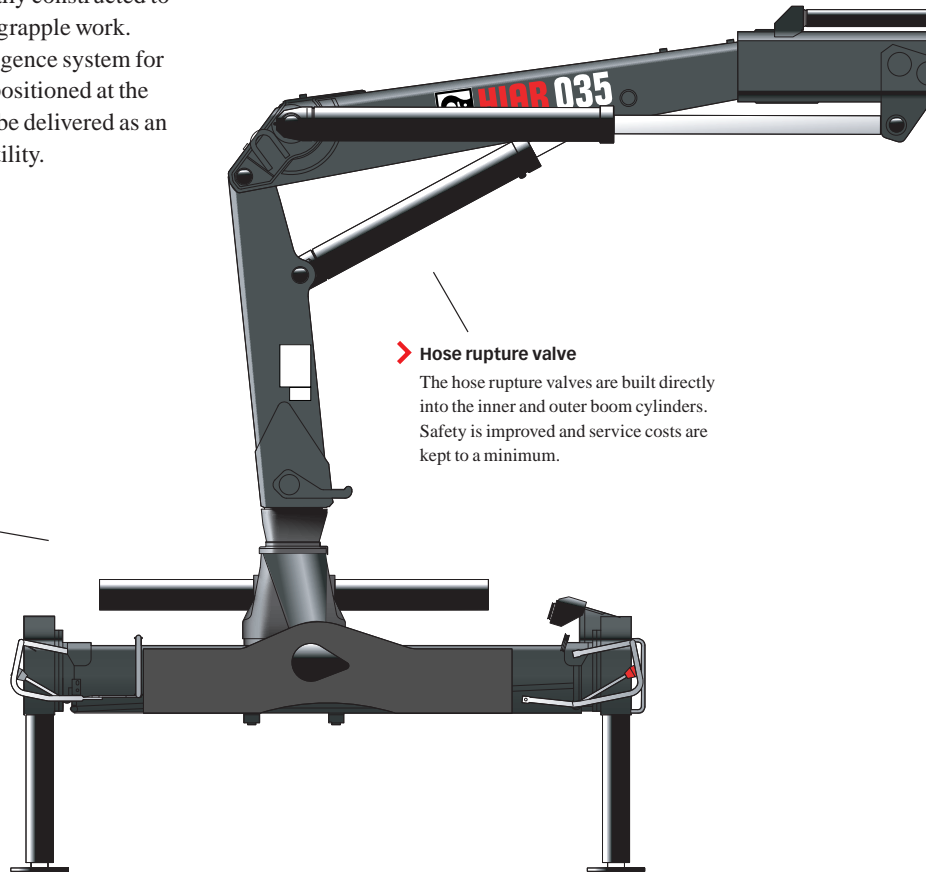

> **Hose rupture valve**

The hose rupture valves are built directly into the inner and outer boom cylinders. Safety is improved and service costs are kept to a minimum.

> **Designing for a long life**

The crane features a rack and pinion slewing mechanism in a cast steel base. A flexible three-point mounting bridge is used for mounting the crane on the truck. This keeps the driving characteristics of the truck unchanged and reduces stress on the chassis, thereby prolonging service life of the truck. Also extra large slide pads are mounted on the boom system, this reduces wear on the extensions and increases operation reliability. The HIAB 035 can be equipped with one or two hydraulic extensions, and up to three manual extensions, providing a maximum total reach of over nine meters.

> **Side controls**

The control panel levers are protected by a steel frame that prevents them from being moved unintentionally. Also indicators showing information from the BOSS safety system are situated directly in the operator's field of vision. As an option your crane can be equipped with cross controls.

> **BOSS safety system**

The BOSS safety system is used on the Hiab light range cranes. It consists of a basic Over Load Protection (OLP) function, making sure your work is always carried out safely. At 90% of the maximum capacity the operator is notified by means of audible and visual alarm signals.

and robust

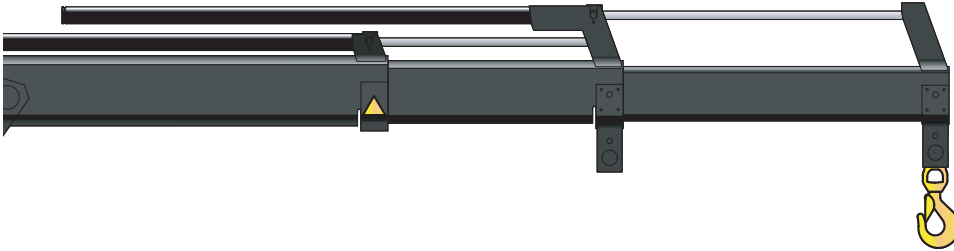

> Hexagonal boom profile

The hexagonal profile ensures the boom is always in perfect balance, thanks to its shape and its big support surface. The profile also minimizes boom deflection. This reduces maintenance costs and increases efficiency.

> Large slide pads

The hexagonal profile enables the use of larger slide pads. This makes the extensions move more smoothly and reduces mechanical wear on the boom.

> Manual extensions

The crane can be equipped with manual boom extensions. These are easily mounted and give an extra outreach that can prove valuable.

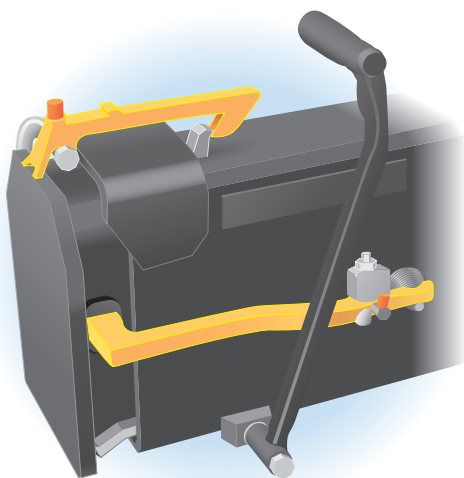

< Cross-controls

The Cross-controls are a Hiab unique feature giving you the same lever sequence on either side of the truck, minimizing the risk of human error. Hiab's safety measures and user-friendly thinking makes life as a crane operator much safer.

< Large slide pads

Large slide pads reduce friction and wear keeping maintenance costs low. Also the Hiab boom system needs no greasing, and thus it is kept cleaner than those of our competitors'.

< Automatic extension-beam lock

The stabilizer extension beams have a spring-loaded mechanical catch that prevents them from sliding out while the truck is on the move. The same type of catch keeps the legs in place when parked.



Hiab is part of Cargotec Corporation



PB-035-EN-EU_080222

